

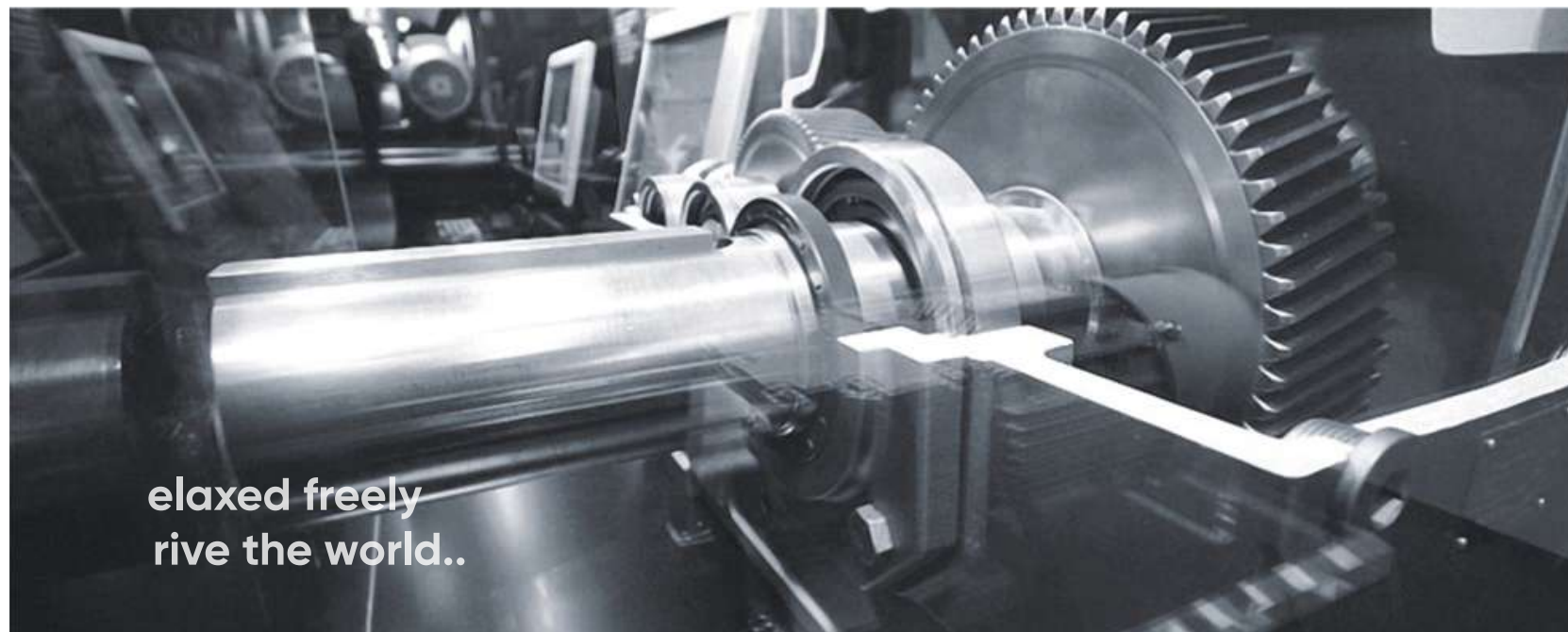

TECHDRIVE
智慧传动专业制造商

浙江华年股份有限公司
ZheJiang WaLand Electrical Motor Co., LTD



elaxed freely
rive the world..

NMRV系列蜗轮蜗杆减速机 NMRV Series Worm Gear Speed Reducer

浙江华年电机股份有限公司
ZheJiang WaLand Electrical Motor Co., LTD
Tel: +8613456727858
Email: steven@walandmotor.com
Add: No. 35, Nansha Road, Qiantang District, Hangzhou

目录

CONTENTS

■ 公司简介	Introduction	2
■ 样册目录	Contents	3

RV系列蜗轮蜗杆减速机 RV Series Worm Gear Speed Reducer

■ 产品图片	Product Picture	5
■ 产品结构图	Product Structure View	6
■ 产品概述	Product Summary	6
■ 选型方法	Service Factor	7
■ NMRV-NRV型号说明	NMRV-NRV Model Notes	9
■ 安装尺寸	Mounting Dimensions	12
■ 选型参数	Parameter Selections	13
■ 外型尺寸	Dimensions	17
■ NMRV-NMRV型号说明	NMRV-NMRV Model Notes	36
■ 选型参数	Parameter Selections	38
■ 外型尺寸	Dimensions	41
■ 附件	Accessories	45
■ 使用说明	Operating Instructions	46
■ 油品润滑	Lubricant	47
■ 故障分析	Malfunctions Analysis	48

RW系列蜗轮蜗杆减速机 RW Series Worm Gear Speed Reducer

■ 型号说明	Description of part number	50
■ 安装型式	Mounting type	50
■ 单向/双向输出轴尺寸	Single / double extension output shaft	53
■ RW / CRW尺寸表	Dimensions for RW / CRW	54

其他系列产品 Other Series Products		55
---------------------------------	--	----



工艺及检测设备

Techincs & testing equipment

拥有高精度的数控机床和加工中心，先进的设备及检测仪器
精良的工艺以及严格完善的质量管理体系
并聚集具有专业技术的精英和领先水平的科技队伍
充分利用新技术、新工艺、新材料保证产品的稳定性和可靠性
产品质量取源于制造手段的先进，精品意识源于不断的创新



产品图片

Product picture



NMRV



NMRV
(For servo motor)



NRV..F



NRV..VS



NRV



NMRV..F



NMRV..VS



NMRV+NMRV

产品结构图 Products Structure View

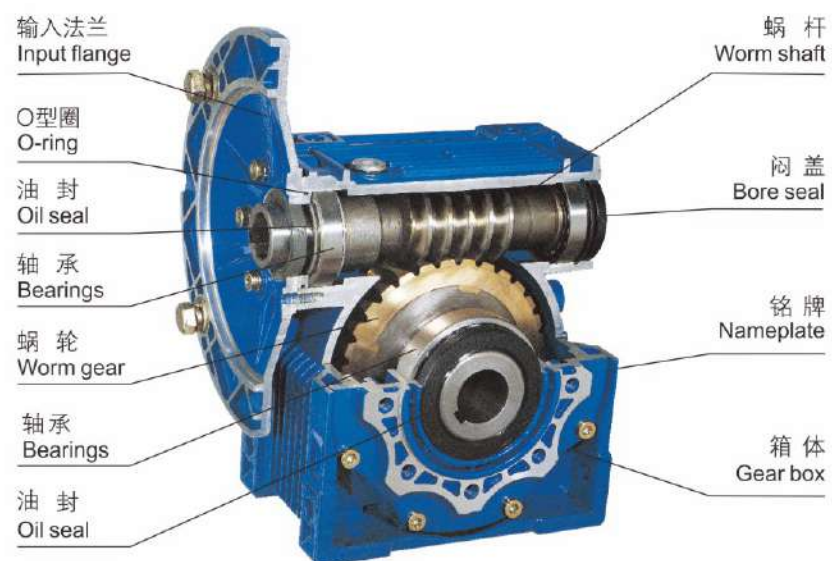

产品概述 Product summary

单级蜗杆减速机

- 采用优质铝合金压铸箱体，外形轻巧美观，结构紧凑，体积小，重量轻，节省安装空间，不易锈蚀。
- 散热性能好，安全可靠，效率高。
- 承载能力高，传动平稳，振动小，噪音低。
- 具有动力输入及转矩输出的多种联接结构，满足多种联接需要；箱体外形设计及底脚孔设置布局适应多种安装方式，通用性强。
- 中小型箱体为全封闭结构，密封性强，箱体内润滑油不易损耗变质，不需更换，便于维护保养。

双级蜗杆减速机

- 由单级蜗杆减速机组合而成，具有单级蜗杆减速机的一切优点，和获得大的传动比。
- 常用双级组合机型为：25/30、25/40、30/40、30/50、30/63、40/75、40/90、50/110、63/130、63/150，用户若有特殊要求时，可根据实际需要选择25、30、40、50、63、75、90、110、130、150作为组合单元另行组合。

Single Step Worm Gear Reducer

- Made of Aluminum alloy die-casting box, good looking in appearance, compact in structure rust proofing on Surface and small volume to save mounting space.
- Good radiating characteristic leads safe and high efficiency for using.
- The strong capacity of loading and overload ensure stable transmission, make less vibration and noise.
- Varies of connecting structure for power input and torque output meet different requirements; the design of box outline and the set of foot hole is apt to with many kinds of mounting.
- Besides big cases, no gap structure of box means a maintenance-free that is hermetically sealed. It prevents the lubricant from easily losing and going bad, and exchanging.

Double Step Worm Gear Reducer

- It is combined by two single step reducers and has all the virtues of them. And you can get bigger ratio with it.
- The models of 25/30、25/40、30/40、30/50、30/63、40/75、40/90、50/110、63/130、63/150, are in common use. You can choose 25、30、40、50、63、75、90、110、130、150 as combination units to combine according to the fact of your special needs.

选型方法 Service factor

为正确选择NMRV蜗杆减速机，敬请用户首先了解以下几点：

- 负荷条件
- 使用转速范围或速比(与双级组合可获得超低输出转速)
- 工作运转情况及环境(温度、湿度、腐蚀等)
- 安装空间

确定工作情况系数K1及工作情况修正系数K2

- 根据表1，决定机械负荷种类A、B、C。
- 根据运转时间(小时/天)和启动频率(次数/小时)从图1中求得工作情况系数K1。
- 根据表2，查取工作情况修正系数K2。

Please read before use:

- Load condition
- Speed of rotation or speed ratio (combination with combine speed reducer can get extra low outputting rotational speed)
- Work circumstance (temperature, humidity, corrosion etc.)
- Space of installation

Ensure coefficient of work condition K1 and coefficient of revise K2

- According to the table 1, choose machinery loading type A, B, C
- According to the working time (h/d) and frequency (times/h) get the coefficient of work condition K1 from table 1
- According to the table 2, pick up coefficient of revise K2

机械负荷种类选定 (表1)
Table 1 machinery load classification selection

使用情况 Using Situation	示例 Example	负荷种类 Load Type
无冲击均匀负荷 Uniform Load	传送带(匀速输送) Convay Band (uniform Conveying)	A(均匀负荷) A(unitorm Load)
中等冲击负荷 Moderate Load	传送带(变速输送) Speed Changed Conveying	B(中等冲击负荷) B(moderate Load)
强烈冲击负荷 Severe Load	压缩机、粉碎机等 Compressor、Pulverizer、etc.	C(强冲击负荷) C(severe Load)

工作情况修正系数K2选定 (表2)
Table 2 working condition coefficient K2

环境温度 Ambient Temperature	工作情况修正系数k2 Working Condition Coefficient K2
-10℃~30℃	1
30℃~40℃	1.1~1.2

工作情况系数K1选定(图1) Diagram 1 working condition coefficient K1

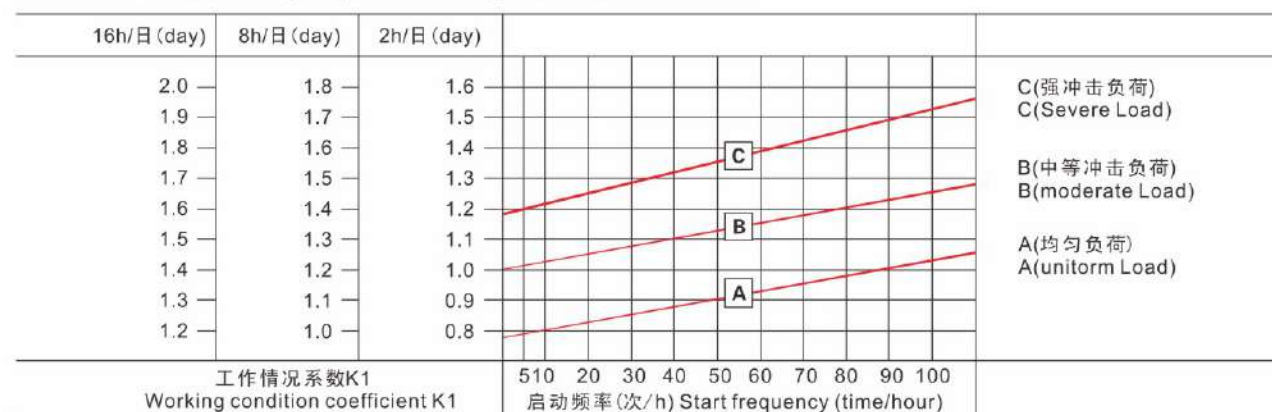

选定减速机

- 用户须先确定工作机输入机械负荷T(转矩)，以T乘以工作情况系数K1，再乘以工作情况修正系数K2，即获得减速机应有的输出转矩值，以此为据，并结合速比值或输出转速值，选定所需减速机规格。
- 用户也可以根据已知的输入功率，结合合理比值或输出转速值，计算输出转矩，选定减速机。

选型示例

例1.通用传送带(均匀负荷)

转矩: 19N.m, 运转时间: 8小时/天,
 转速: 约55r/min, 启动频率: 10次/小时,
 减速机: 1/25, 环境温度: 室内25℃, 电机直联

- ①根据表1,决定负荷种类
 负荷种类:无冲击均匀负荷, 选A;
- ②根据图1,在A线上取频率10次/小时的交点, 求出运转时间8小时/天的系数K1=1;
- ③根据表2, 查得系数K2=1;
- ④则转矩值为 $19 \times K1 \times K2 = 19 \times 1 \times 1 = 19 \text{ N.m}$, 可选择最接近19 N.m的减速机。
 选定结果: NMRV30-1/25
 输入功率0.18kW, 输出转速56转/分, 输出转矩21 N.m

例2. 输送带(中等冲击负荷)

转矩: 65N.m, 运转时间: 16小时/天,
 转速: 约21 r/min, 启动频率: 100次/小时,
 减速机: 1/60, 环境温度: 室内35℃, 电机直联

- ①根据表1, 决定负荷种类
 负荷种类:轻度冲击负荷, 选B;
- ②根据图1, 在B线上取频率100次/小时的交点, 求出运转时间16小时/天的系数K1 = 1.65;
- ③根据表2, 查得系数K2=1.15;
- ④则转矩值为 $65 \times K1 \times K2 = 70 \times 1.65 \times 1.15 = 123 \text{ N.m}$, 可选择最接近123 N.m的减速机。
 选定结果: NMRV63-1/60
 输入功率0.55kW, 输出转速23.3转/分, 输出转矩140N.m

How to select

- At first, to ensure the value of input machinery load T(torque), multiple K1 and K2 by T, then you can get the value of output torque, on the basis of which, also consider speed of output rotation or speed ratio then you can choose specification.
- You can calculate the output torque based on the known input power, reasonable ratio or speed of output rotation, then you can choose specification.

Example for model selection

Ex1. General conveyor belt (uniform load)

Torque: 19N.m Turning time: 8hs/day
 Speed of rotation: about 55r/min start frequency: 10times/h
 Ratio:1/25 Temperature:25℃ (indoor) Connect with motor direct

- ①According to the table 1,ensure type of load
 Type of load: load-bearing uniform without impact, choose A;
- ②According to diagram 1, choose the point 10times/h on the intersection A, we can get the K1=1 of turning time 8hs/d;
- ③According to the table 2,get the K2=1;
- ④The value of torque is $19 \times K1 \times K2 = 19 \times 1 \times 1 = 19 \text{ N.m}$, choose the closest 19N.m reducer.
 Choose selection: NMRV30-1/25
 Input power = 0.18kw, the speed of output rotation is= 56r/min,
 the value of output torque is 21N.m

Ex2.conveying belt(moderate load)

Torque:65N.m Turning time:16hs/d
 Speed of rotation:about 21r/min Start frequency:100times/h
 Ratio:1/60 Temperature:35℃ (indoor) Connect with motor direct

- ①According to the table 1,ensure type of load
 Type of load: light load-bearing, choose B;
- ②According to diagram 1, choose the point 100times/h on the intersection B,then you can get the K1=1.65 of turning time16hs/d;
- ③According to the table 2,get the K2=1.15;
- ④The value of torque is $65 \times K1 \times K2 = 70 \times 1.65 \times 1.15 = 123 \text{ N.m}$, choose the closest 123N.m reducer..
 Choose selection: NMRV63-1/60
 Input power = 0.55kw, the speed of output rotation =23.3r/min,the value of output torque is 140N.m

NMRV/NRV

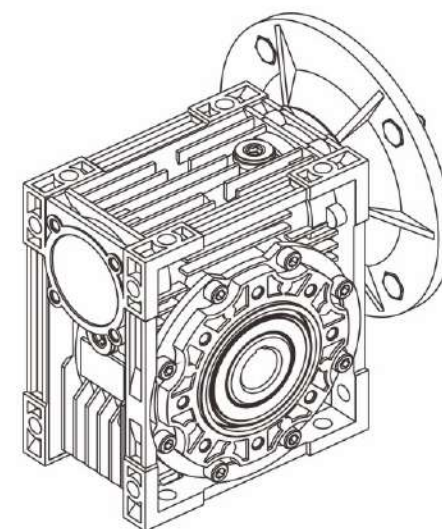

NMRV

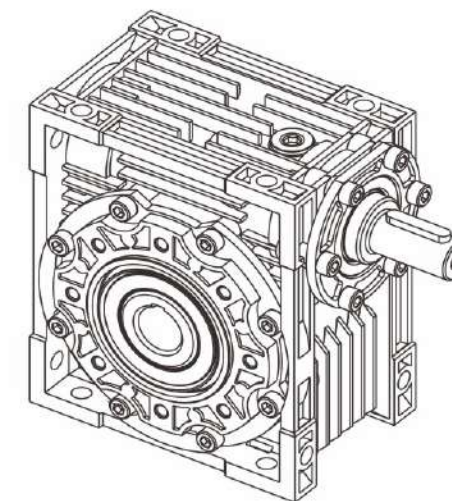

NRV

型号说明 Model notes

NMRV-063-30-VS-F1 (FA)-AS-80B5-0.55kW-B3			
NMRV	蜗轮减速机 Worm gear speed reducer		
NRV	蜗轮减速机(配接输入轴) Worm gear speed reducer (Mounting input shaft)		
063	蜗轮减速机中心距 Center distance		
30	减速比 Reduction ratio		
VS	双向输入轴 Double input shaft	F1 (FA)	输出法兰位置及型号 Output flange
AS	单向输出轴 Single output shaft	AB	双向输出轴 Double output shaft
PAM	电机联接 Fitted for motor coupling	80B5	电机机座号和安装结构形式 Motor mounting facility
0.55kW	电机功率 Electric motor power	B3	安装方位 Mounting position

国内外型号对照 Comparative table of model

本企业 Our enterprise	NMRV025	NMRV030	NMRV040	NMRV050	NMRV063	NMRV075	NMRV090	NMRV110	NMRV130	NMRV150
		NRV030	NRV040	NRV050	NRV063	NRV075	NRV090	NRV110	NRV130	NRV150
国内企业 Domestic	NMRV025	NMRV030	NMRV040	NMRV050	NMRV063	NMRV075	NMRV090	NMRV110	NMRV130	NMRV150
		NRV030	NRV040	NRV050	NRV063	NRV075	NRV090	NRV110	NRV130	NRV150
	WJ25	WJ30	WJ40	WJ50	WJ63	WJ75	WJ90	WJ110	WJ130	WJ150
	FCNDK25	FCNDK30	FCNDK40	FCNDK50	FCNDK63	FCNDK75	FCNDK90	FCNDK110	FCNDK130	FCNDK150
		FCNK30	FCNK40	FCNK50	FCNK63	FCNK75	FCNK90	FCNK110	FCNK130	FCNK150
	JRSTD025	JRSTD030	JRSTD040	JRSTD050	JRSTD063	JRSTD075	JRSTD090	JRSTD110	JRSTD130	JRSTD150
	JRST030	JRST040	JRST050	JRST063	JRST075	JRST090	JRST110	JRST130	JRST150	

单级安装型式 Single Step Mounting Positions

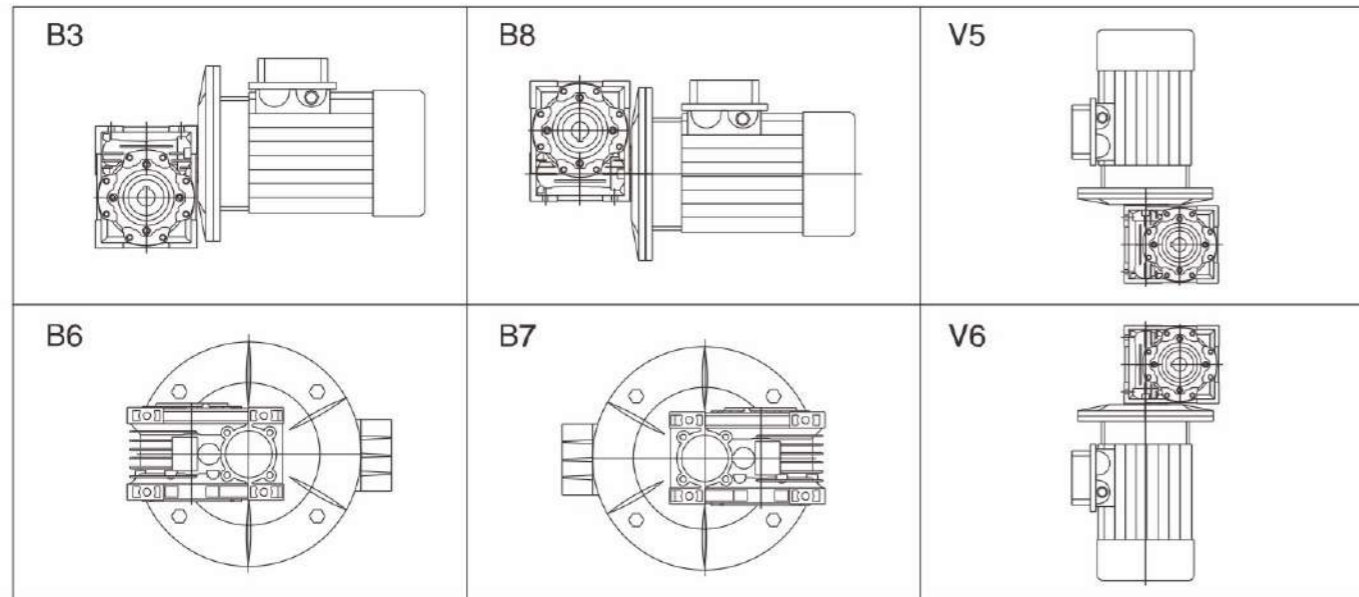

接线盒安装方式 Position of terminal box

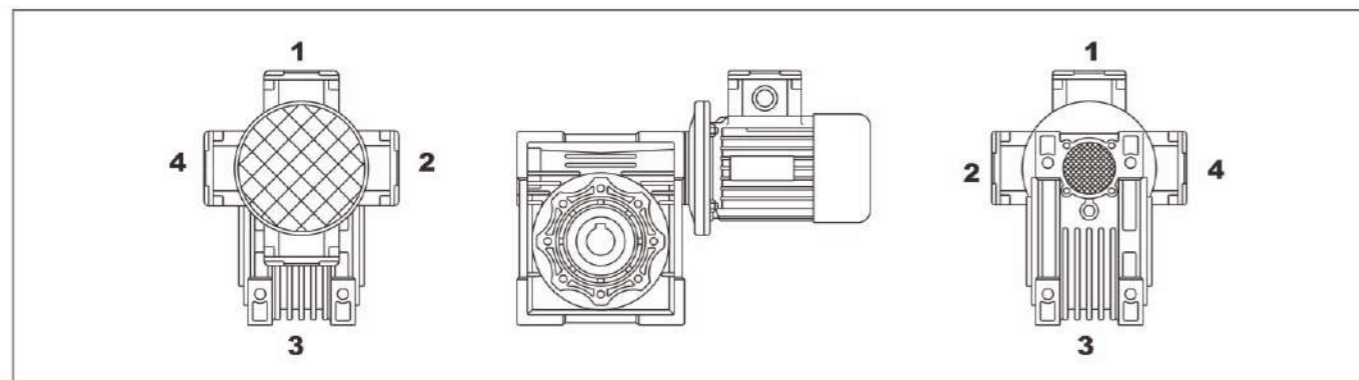

输出轴配置 Position of output shaft

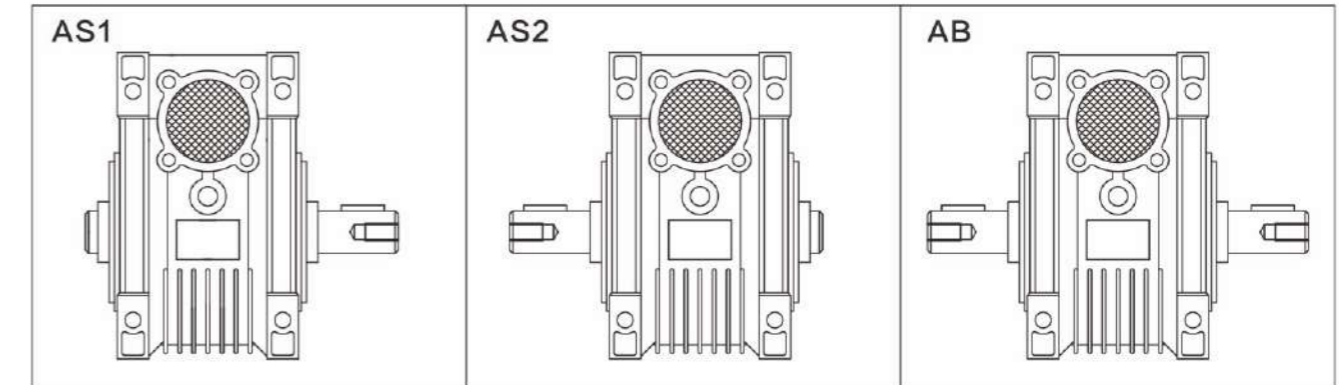

双向输入轴
Double extension worm shaft

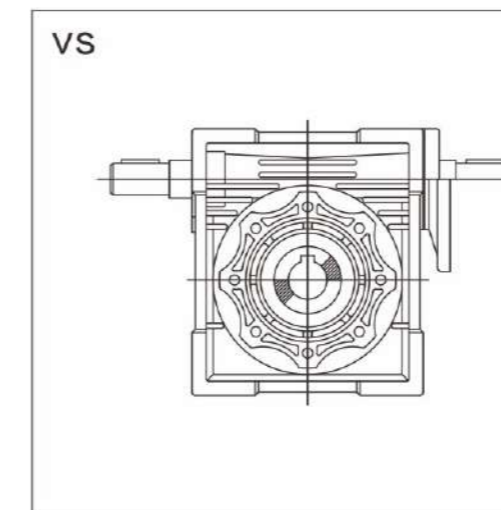

扭力臂配置
Position of torque arm

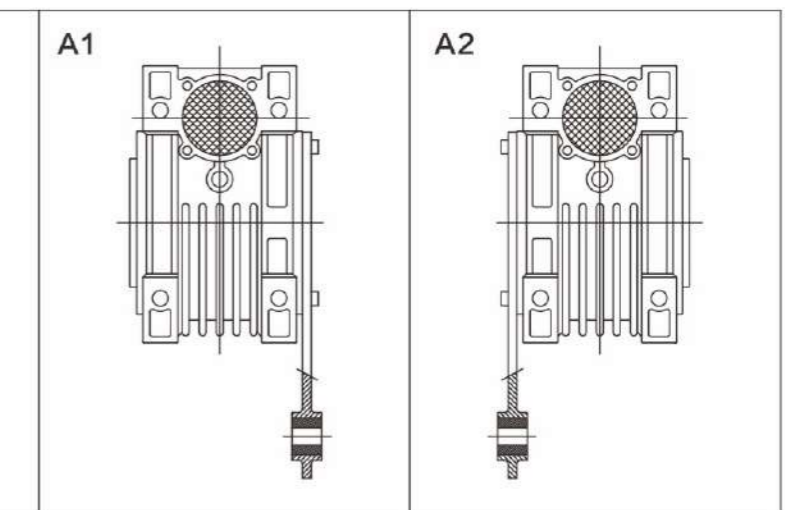

法兰位置 Flange F-FL

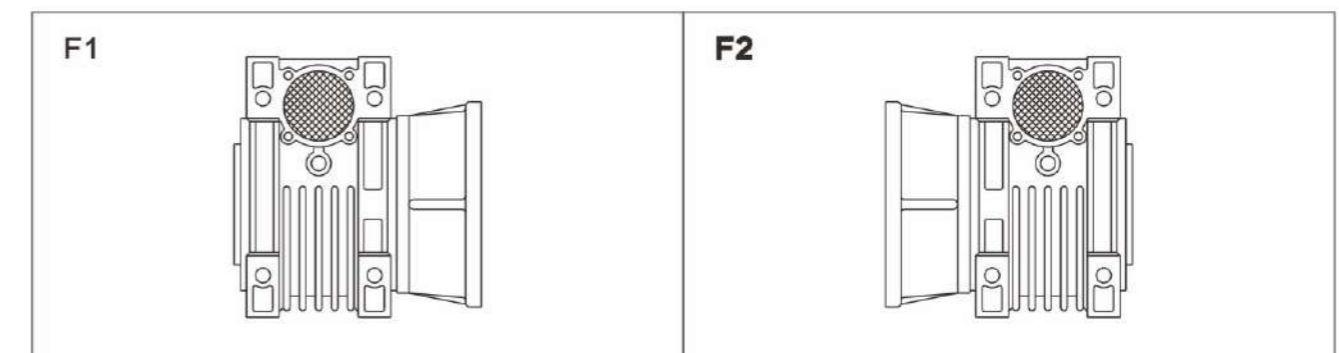

安装尺寸 Mounting dimensions

单级蜗杆减速机
Single step worm gear reducer

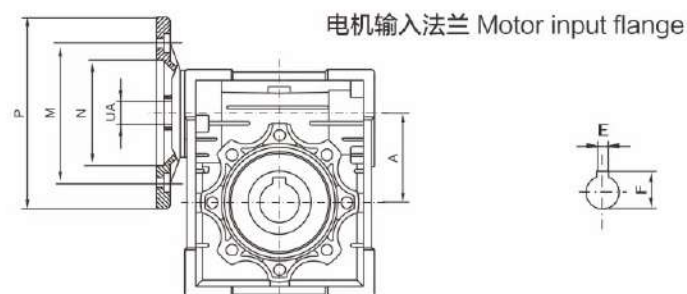

中心距 Center Distance A	电机法兰 Motor Flange						输入轴孔直径UA The Hole Diameter of Shaft											
	PAM IEC	N	M	P	E	F	传动比 i Transmission Ratio											
							5	7.5	10	15	20	25	30	40	50	60	80	100
NMRV025	56B14	50	65	80	3	10.4	9	9	9	9	9	-	9	9	9	9	-	-
NMRV030	63B5	95	115	140	4	12.8	11	11	11	11	11	11	11	11	11	11	11	11
	63B14	60	75	90														
	56B5	80	100	120														
NMRV040	56B14	50	65	80	3	10.4	9	9	9	9	9	9	9	9	9	9	9	9
	71B5	110	130	160														
	71B14	70	85	105														
NMRV050	63B5	95	115	140	4	12.8	11	11	11	11	11	11	11	11	11	11	11	11
	63B14	60	75	90														
	56B5	80	100	120														
NMRV063	80B5	130	165	200	6	21.8	19	19	19	19	19	19	19	19	19	19	19	19
	80B14	80	100	120														
	71B5	110	130	160														
NMRV075	71B14	70	85	105	5	16.3	14	14	14	14	14	14	14	14	14	14	14	14
	100/112B5	180	215	250														
	100/112B14	110	130	160														
NMRV090	90B5	130	165	200	8	27.3	24	24	24	24	24	24	24	24	24	24	24	24
	90B14	95	115	140														
	80B5	130	165	200														
NMRV110	80B14	80	100	120	6	21.8	-	-	-	-	-	-	-	-	-	-	-	-
	132B5	230	265	300														
	132B14	130	165	200														
NMRV130	100/112B5	180	215	250	8	31.3	-	-	-	-	-	-	-	-	-	-	-	-
	90B5	130	165	200														
	90B14	95	115	140														
NMRV150	80B5	130	165	200	6	21.8	-	-	-	-	-	-	-	-	-	-	-	-
	132B5	230	265	300														
	132B14	130	165	200														
NMRV150	100/112B5	180	215	250	8	31.3	-	-	-	-	-	-	-	-	-	-	-	-
	160B5	250	300	350														
	132B14	130	165	200														

选型参数 Parameter selections

单级减速机(法兰输入, 输入转速1400r/min)/(配4极电机)
Single step reducer (flange input, input speed is 1400r/min)/(matched with 4 poles motor)

机型号 Model	输出转速 N2 (r/min)	输出转矩 M2 (N.m)	传动比 i	输出轴 径向力 kN	使用系数 f.s.	
0.06kw						
NMRV25	186.7	2.6	7.5	0.50	4.2	
	140	3.4	10	0.55	3.5	
	93.3	4.9	15	0.63	2.5	
	70	6.1	20	0.69	2.0	
	46.7	8.2	30	0.79	1.6	
	35	10	40	0.87	1.3	
	28	12	50	0.94	0.9	
	23.3	14	60	1.00	0.7	
	NMRV30	186.7	2.6	7.5	0.68	6.9
		140	3.4	10	0.75	5.4
93.3		4.7	15	0.86	3.8	
70		6	20	0.94	3.0	
56		7	25	1.02	3.0	
46.7		8	30	1.08	2.5	
35		9.7	40	1.19	1.9	
28		11	50	1.28	1.5	
23.3		13	60	1.36	1.3	
17.5		14	80	1.50	0.9	
0.09kw						
NMRV25	186.7	3.9	7.5	0.50	2.8	
	140	5.1	10	0.55	2.4	
	93.3	7.3	15	0.63	1.6	
	70	9.2	20	0.69	1.3	
	46.7	12	30	0.79	1.1	
	35	15	40	0.87	0.9	
NMRV30	186.7	3.9	7.5	0.68	4.6	
	140	5	10	0.75	3.6	
	93.3	7.1	15	0.86	2.5	
	70	9	20	0.94	2.0	
	56	10	25	1.02	2.0	
	46.7	12	30	1.08	1.7	
NMRV40	35	14	40	1.19	1.2	
	28	17	50	1.28	1.0	
	23.3	19	60	1.36	0.9	
	28	19	50	2.47	2.0	
	23.3	21	60	2.63	1.7	
	17.5	26	80	2.89	1.3	
0.12kw						
NMRV30	186.7	5.2	7.5	0.68	3.4	
	140	6.7	10	0.75	2.7	
	93.3	9.5	15	0.86	1.9	
	70	12	20	0.94	1.5	
	56	14	25	1.02	1.5	
	46.7	16	30	1.08	1.3	
NMRV40	35	19	40	1.19	0.9	
	28	23	50	1.28	0.8	
	46.7	17.2	30	2.08	2.6	
NMRV40	35	21	40	2.29	1.9	

机型号 Model	输出转速 N2 (r/min)	输出转矩 M2 (N.m)	传动比 i	输出轴 径向力 kN	使用系数 f.s.
0.12kw					
NMRV40	28	25	50	2.47	1.5
	23.3	28	60	2.63	1.3
	17.5	34	80	2.89	1.0
	14	38	100	3.11	0.8
NMRV50	23.3	29	60	3.61	2.3
	17.5	35	80	3.97	1.9
	14	40	100	4.28	1.4
0.18kw					
NMRV30	186.7	7.8	7.5	0.68	2.3
	140	10	10	0.75	1.8
	93.3	14	15	0.86	1.3
	70	18	20	0.94	1.0
	56	21	25	1.02	1.0
	46.7	24	30	1.08	0.8
NMRV40	70	19	20	1.82	2.0
	56	23	25	1.96	1.7
	46.7	26	30	2.08	1.7
	35	32	40	2.29	1.3
	28	38	50	2.47	1.0
	23.3	43	60	2.63	0.8
NMRV50	35	32	40	3.15	2.3
	28	39	50	3.39	1.9
	23.3	43	60	3.61	1.6
	17.5	52	80	3.97	1.2
	14	60	100	4.28	0.9
	0.25kw				
NMRV40	186.7	11	7.5	1.31	3.6
	140	14	10	1.44	2.8
	93.3	21	15	1.65	1.9
	70	27	20	1.82	1.5
	56	32	25	1.96	1.2
	46.7	36	30	2.08	1.3
NMRV50	35	44	40	2.29	0.9
	28	37	50	2.47	0.8
	70	26	20	2.50	2.7
	56	32	25	2.69	2.2
	46.7	37	30	2.86	2.3
	35	46	40	3.15	1.7
NMRV63	28	54	50	3.39	1.4
	23.3	60	60	3.61	1.1
	17.5	72	80	3.97	0.9
	28	56	50	4.44	2.4
	23.3	63	60	4.71	2.0
	17.5	78	80	5.19	1.6
0.37kw					
NMRV40	186.7	16	7.5	1.31	2.4
	140	21	10	1.44	1.9
	93.3	31	15	1.65	1.3

机型代号 Model	输出转速 N ₂ (r/min)	输出转矩 M ₂ (N.m)	传动比 i	输出轴 径向力 kN	使用系数 f.s.
0.37kw					
NMRV40	70	39	20	1.82	1.0
	56	47	25	1.96	0.8
	46.7	53	30	2.08	0.8
NMRV50	140	21	10	1.98	3.3
	93.3	31	15	2.27	2.4
	70	40	20	2.5	1.8
	56	48	25	2.69	1.5
	46.7	55	30	2.86	1.5
	35	68	40	3.15	1.1
	28	80	50	3.39	0.9
	23.3	89	60	3.61	0.8
NMRV63	35	70	40	4.12	2.1
	28	83	50	4.44	1.6
	23.3	94	60	4.71	1.4
	17.5	115	80	5.19	1.1
	14	129	100	5.59	0.9
0.55kw					
NMRV50	186.7	25	7.5	1.8	2.9
	140	32	10	1.98	2.2
	93.3	46	15	2.27	1.6
	70	59	20	2.5	1.2
	56	71	25	2.69	1.0
	46.7	81	30	2.86	1.0
	35	80	40	3.15	0.9
NMRV63	70	60	20	3.27	2.2
	56	73	25	3.52	1.8
	46.7	83	30	3.74	1.9
	35	105	40	4.12	1.4
	28	124	50	4.44	1.1
	23.3	140	60	4.71	0.9
NMRV75	35	108	40	4.86	2.0
	28	129	50	5.24	1.6
	23.3	146	60	5.56	1.4
	17.5	180	80	6.13	1.1
	14	206	100	6.60	0.9
NMRV90	17.5	189	80	6.78	1.5
	14	221	100	7.30	1.2
0.75kw					
NMRV50	186.7	34	7.5	1.80	2.1
	140	44	10	1.98	1.6
	93.3	63	15	2.27	1.2
	70	81	20	2.50	0.9
NMRV63	93.3	63	15	2.97	2.2
	70	83	20	3.27	1.6
	56	100	25	3.52	1.3
	46.7	114	30	3.74	1.4
	35	143	40	4.12	1.0
NMRV75	56	102	25	4.16	2.0
	46.7	117	30	4.42	2.0
	35	147	40	4.86	1.5
	28	177	50	5.24	1.2
	23.3	200	60	5.56	1.0
NMRV90	28	184	50	5.79	1.8
	23.3	212	60	6.16	1.5

机型代号 Model	输出转速 N ₂ (r/min)	输出转矩 M ₂ (N.m)	传动比 i	输出轴 径向力 kN	使用系数 f.s.
0.75kw					
NMRV90	17.5	258	80	6.78	1.1
	14	302	100	7.30	0.9
1.1kw					
NMRV63	186.7	49	7.5	2.35	2.6
	140	65	10	2.59	2.0
	93.3	93	15	2.97	1.5
	70	122	20	3.27	1.1
	56	146	25	3.52	0.9
	46.7	167	30	3.74	1.0
	35	165	40	3.59	0.9
NMRV75	93.3	95	15	3.50	2.1
	70	123	20	3.86	1.7
	56	150	25	4.16	1.3
	46.7	171	30	4.42	1.3
	35	216	40	4.86	1.0
	28	264	50	4.60	0.9
	23.3	223	60	4.89	0.8
NMRV90	35	225	40	5.38	1.6
	28	270	50	5.79	1.3
	23.3	311	60	6.16	1.0
	17.5	328	80	6.17	0.9
NMRV110	28	281	50	7.32	2.3
	23.3	324	60	7.78	1.9
	17.5	402	80	8.57	1.3
	14	473	100	9.23	1.0
1.5kw					
NMRV63	186.7	67	7.5	2.35	1.9
	140	89	10	2.59	1.5
	93.3	127	15	2.97	1.1
	70	166	20	3.27	0.8
NMRV75	140	90	10	3.06	2.2
	93.3	130	15	3.50	1.5
	70	168	20	3.86	1.3
	56	205	25	4.16	1.0
	46.7	233	30	4.42	1.0
NMRV90	70	171	20	4.27	2.1
	56	210	25	4.60	1.6
	46.7	239	30	4.89	1.7
	35	307	40	5.38	1.2
	28	368	50	5.79	0.9
	23.3	424	60	6.16	0.8
NMRV110	35	319	40	6.80	2.2
	28	384	50	7.32	1.7
	23.3	442	60	7.78	1.4
	17.5	548	80	8.57	0.9
2.2kw					
NMRV75	186.7	100	7.5	2.78	1.8
	140	132	10	3.06	1.5
	93.3	191	15	3.50	1.0
	70	240	20	3.38	0.9
	46.7	269	30	3.89	0.8
NMRV90	186.7	101	7.5	3.08	2.9
	140	134	10	3.39	2.3
	93.3	194	15	3.88	1.9

机型代号 Model	输出转速 N ₂ (r/min)	输出转矩 M ₂ (N.m)	传动比 i	输出轴 径向力 kN	使用系数 f.s.
2.2kw					
NMRV90	70	252	20	4.27	1.4
	56	308	25	4.60	1.1
	46.7	351	30	4.89	1.2
	35	433	40	4.90	1.0
	28	393	50	5.28	0.9
NMRV110	70	255	20	5.39	2.5
	56	315	25	5.81	2.2
	46.7	356	30	6.18	2.0
	35	468	40	6.8	1.5
	28	563	50	7.32	1.2
	23.3	648	60	7.78	1.0
NMRV130	35	468	40	8.89	2.2
	28	563	50	9.58	1.7
	23.3	648	60	10.18	1.4
	17.5	816	80	11.21	1.0
	14	869	100	10.62	0.8
NMRV150	28	570	50	13.10	2.5
	23.3	657	60	13.92	1.9
	17.5	816	80	15.32	1.4
	14	960	100	16.50	1.0
3kw					
NMRV75	186.7	136	7.5	2.78	1.4
	140	180	10	3.06	1.1
	93.3	261	15	3.50	0.8
NMRV90	186.7	138	7.5	3.08	2.1
	140	182	10	3.39	1.7
	93.3	264	15	3.88	1.4
	70	344	20	4.27	1.0
	56	420	25	4.60	0.8
	46.7	479	30	4.89	0.9
NMRV110	93.3	264	15	4.90	2.5
	70	348	20	5.39	1.9
	56	430	25	5.81	1.6
	46.7	485	30	6.18	1.5
	35	638	40	6.80	1.1
	28	767	50	7.32	0.9
NMRV130	56	429	25	7.60	2.2
	46.7	491	30	8.08	2.1
	35	638	40	8.89	1.6
	28	767	50	9.58	1.3
	23.3	884	60	10.18	1.0
	17.5	1113	80	11.21	0.8
NMRV150	28	777	50	13.10	1.8
	23.3	896	60	13.92	1.4
	17.5	1113	80	15.32	1.0
	14	1310	100	16.50	0.8
4kw					
NMRV75	186.7	182	7.5	2.44	1.4
NMRV90	186.7	184	7.5	3.08	1.6
	140	243	10	3.39	1.3
	93.3	352	15	3.88	1.0
	70	458	20	4.27	0.8
NMRV110	140	242	10	4.28	2.5
	93.3	352	15	4.90	1.9
	70	464	20	5.39	1.4

机型代号 Model	输出转速 N ₂ (r/min)	输出转矩 M ₂ (N.m)	传动比 i	输出轴 径向力 kN	使用系数 f.s.
4kw					
NMRV110	56	573	25	5.81	1.2
	46.7	647	30	6.18	1.1
NMRV130	56	573	25	7.60	1.6
	46.7	655	30	8.08	1.6
	35	851	40	8.89	1.2
	28	1023	50	9.58	1.0
	23.3	1179	60	10.18	0.8
NMRV150	28	1036	50	13.10	1.4
	23.3	1195	60	13.92	1.1
	17.5	1484	80	15.32	0.8
5.5kw					
NMRV110	186.7	253	7.5	3.89	2.2
	140	334	10	4.28	1.8
	93.3	484	15	4.90	1.4
	70	638	20	5.39	0.9
	56	711	25	5.15	1.0
NMRV130	140	333	10	5.60	2.5
	93.3	490	15	6.41	1.9
	70	645	20	7.06	1.4
	56	788	25	7.60	1.2
	46.7	900	30	8.08	1.2
	35	1171	40	8.89	0.9
	28	1103	50	8.51	0.8
NMRV150	70	645	20	9.65	2.0
	56	788	25	10.40	1.5
	46.7	934	30	11.05	1.3
	35	1171	40	12.16	1.3
	28	1426	50	13.10	1.0
	23.3	1643	60	13.92	0.8
7.5kw					
NMRV110	186.7	345	7.5	3.89	1.6
	140	455	10	4.28	1.3
	93.3	660	15	4.90	1.0
NMRV130	186.7	349	7.5	5.09	2.1
	140	455	10	5.6	1.8
	93.3	668	15	6.41	1.4
	70	880	20	7.06	1.0
	56	1074	25	7.6	0.9
	46.7	1228	30	8.08	0.8
	35	1596	40	8.89	0.7
NMRV150	70	880	20	9.65	1.5
	56	1074	25	10.4	1.1
	46.7	1274	30	11.05	0.9
	35	1596	40	12.16	1.0
11kw					
NMRV150	186.7	512	7.5	6.96	2.3
	140	675	10	7.66	1.8
	93.3	990	15	8.77	1.3
	70	1291	20	9.65	1.0
	56	1576	25	10.4	0.8
15kw					
NMRV150	186.7	698	7.5	6.96	1.7
	140	921	10	7.66	1.3
	93.3	1351	15	8.77	0.9
	70	1760	20	9.65	0.7

单级减速机(轴伸输入, 输入转速1400r/min)

Single step reducer (shaft extend input, input speed is 1400r/min)

机型号 Model	输入轴 功率 kw	输出转速 N ₂ (r/min)	输出转矩 M ₂ (N.m)	传动比 i	输出轴 径向力 kN	输出轴 径向力 kN
NRV30	0.4	186.7	18	7.5	0.68	0.15
	0.3	140	18	10	0.75	0.16
	0.2	93.3	18	15	0.86	0.16
	0.2	70	18	20	0.94	0.19
	0.2	56	21	25	1.02	0.21
	0.2	46.7	20	30	1.08	0.21
	0.1	35	18	40	1.19	0.21
	0.1	28	17	50	1.28	0.21
	0.1	23.3	16	60	1.36	0.21
NRV40	0.9	186.7	40	7.5	1.31	0.29
	0.7	140	40	10	1.44	0.33
	0.5	93.3	40	15	1.65	0.33
	0.4	70	39	20	1.82	0.35
	0.3	56	38	25	1.96	0.35
	0.3	46.7	45	30	2.08	0.35
	0.2	35	41	40	2.29	0.35
	0.2	28	39	50	2.47	0.35
	0.2	23.3	36	60	2.63	0.35
	0.1	17.5	33	80	2.89	0.35
	0.1	14	29	100	3.11	0.35
	NRV50	1.6	186.7	71	7.5	1.80
1.2		140	72	10	1.98	0.49
0.9		93.3	74	15	2.27	0.49
0.7		70	73	20	2.50	0.49
0.5		56	70	25	2.69	0.49
0.6		46.7	84	30	2.86	0.49
0.4		35	76	40	3.15	0.49
0.3		28	73	50	3.39	0.49
0.3		23.3	68	60	3.61	0.49
0.2		17.5	65	80	3.97	0.49
0.2		14	55	100	4.28	0.49
NRV63		2.8	186.7	128	7.5	2.35
	2.2	140	130	10	2.59	0.57
	1.6	93.3	140	15	2.97	0.61
	1.2	70	135	20	3.27	0.66
	1.0	56	130	25	3.52	0.70
	1.1	46.7	160	30	3.74	0.70
	0.8	35	145	40	4.12	0.70
	0.6	28	135	50	4.44	0.70
	0.5	23.3	130	60	4.71	0.70
	0.4	17.5	122	80	5.19	0.70
	0.3	14	118	100	5.59	0.70
	NRV75	4.1	186.7	185	7.5	2.78
3.2		140	195	10	3.06	0.83
2.3		93.3	200	15	3.50	0.85
1.9		70	210	20	3.86	0.98
1.5		56	200	25	4.16	0.98
1.5		46.7	230	30	4.42	0.98

机型号 Model	输入轴 功率 kw	输出转速 N ₂ (r/min)	输出转矩 M ₂ (N.m)	传动比 i	输出轴 径向力 kN	输出轴 径向力 kN	
NRV75	1.1	35	220	40	4.86	0.98	
	0.9	28	210	50	5.24	0.98	
	0.8	23.3	200	60	5.56	0.98	
	0.6	17.5	190	80	6.13	0.98	
	0.5	14	180	100	6.60	0.98	
	NRV90	6.3	186.7	290	7.5	3.08	0.90
5.1		140	310	10	3.39	1.08	
4.1		93.3	360	15	3.88	1.25	
2.4		56	340	25	4.60	1.27	
2.6		46.7	410	30	4.89	1.27	
1.8		35	360	40	5.38	1.27	
1.4		28	340	50	5.79	1.27	
1.1		23.3	320	60	6.16	1.27	
0.8		17.5	285	80	6.78	1.27	
0.7		14	270	100	7.30	1.27	
NRV110		12	186.7	552	7.5	3.89	1.20
		9.8	140	598	10	4.28	1.46
	7.5	93.3	656	15	4.90	1.60	
	5.6	70	644	20	5.39	1.70	
	4.7	56	679	25	5.81	1.70	
	4.5	46.7	725	30	6.18	1.70	
	3.3	35	702	40	6.80	1.70	
	2.6	28	660	50	7.32	1.70	
	2.1	23.3	616	60	7.78	1.70	
	1.4	17.5	515	80	8.57	1.70	
	1.1	14	483	100	9.23	1.70	
	NRV130	16.1	186.7	750	7.5	5.09	1.50
13.5		140	820	10	5.60	1.84	
10.3		93.3	920	15	6.41	2.07	
7.8		70	910	20	7.06	2.10	
6.5		56	930	25	7.60	2.10	
6.4		46.7	1040	30	8.08	2.10	
4.9		35	1050	40	8.89	2.10	
3.8		28	980	50	9.58	2.10	
3.1		23.3	900	60	10.18	2.10	
2.3		17.5	840	80	11.21	2.10	
1.7		14	740	100	12.07	2.10	
NRV150		25.8	186.7	1200	7.5	6.96	1.95
	20.2	140	1240	10	7.66	2.26	
	13.9	93.3	1250	15	8.77	2.28	
	11.1	70	1300	20	9.65	2.67	
	8.4	56	1200	25	10.40	2.80	
	7.1	46.7	1200	30	11.05	2.80	
	7.3	35	1550	40	12.16	2.80	
	5.4	28	1400	50	13.10	2.80	
	4.2	23.3	1260	60	13.92	2.80	
	3.1	17.5	1150	80	15.32	2.80	
	2.3	14	1000	100	16.50	2.80	

减速机外型尺寸 Dimensions

025

NMRV

Input shaft details: Input bore diameter UA = 9, Key width E = 3, Flange diameter P = 80, Flange type: 圆法兰 (Circular Flange).

Output shaft details: Shaft diameter AB = 11g6, Key width AS = 4, Flange diameter VS = 96, Flange type: 圆法兰 (Circular Flange).

Weight: 重量 Weight: 0.7kg

中心距 Center Distance A	法兰型式 Flange Type	电机法兰 Motor Flange					
		法兰规格 PAM IEC	止口 N	对角螺丝孔距 M	法兰直径 P	键槽 E	输入轴孔直径 UA Input Shaft Hole Diameter
25	圆法兰	56B14	50	65	80	3	9

减速机外型尺寸 Dimensions

NMRV

030

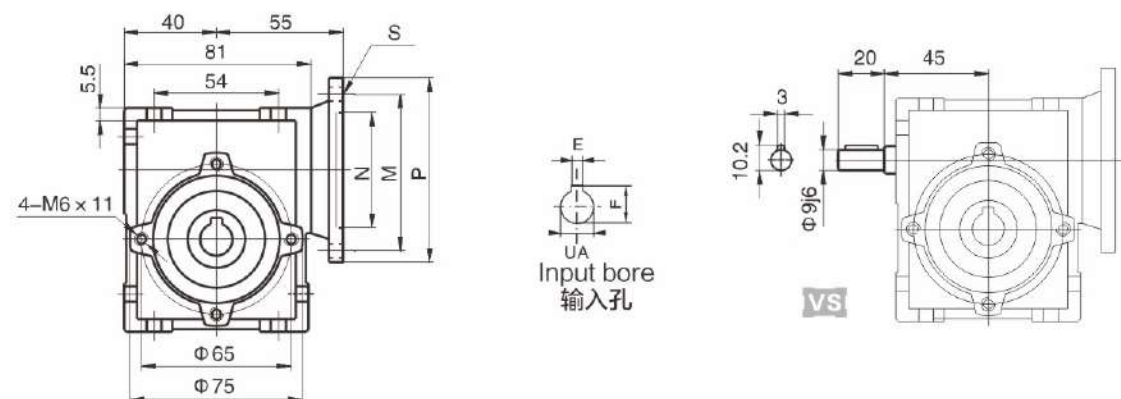

圆法兰

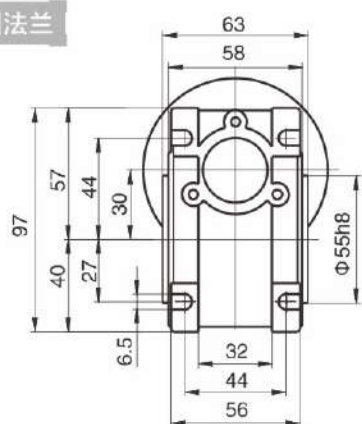

方法兰

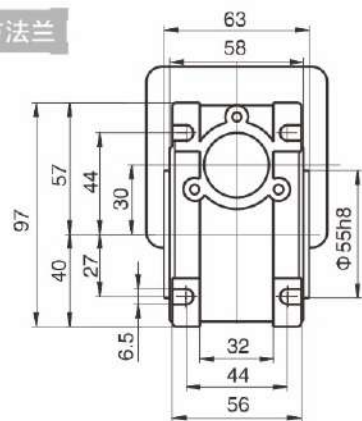

中心距: Center Distance A	法兰型式 Flange Type	电机法兰 Motor Flange					
		法兰规格 PAM IEC	止口 N	对角螺丝孔距 M	法兰直径 P	键槽 E	输入轴孔直径UA Input Shaft Hole Diameter
30	圆法兰	63B5	95	115	140	3, 4	9, 11
		63B14	60	75	90		
		56B5	80	100	120		
		56B14	50	65	80		
30	方法兰	电机法兰 Motor Flange					
		法兰规格 PAM IEC	止口 N	对角螺丝孔距 M	法兰边长 P	键槽 E	输入轴孔直径UA Input Shaft Hole Diameter
		57×57	38	67	57		
		60×60	40, 50	67	60		
		80×80	60, 70, 73	94	80		
		86×86	60, 70, 73	95(U型螺丝孔)	86		
	90×90	80, 83	104(U型螺丝孔)	90			
104×104	94, 95, 98	120(U型螺丝孔)	104				
偏心方法兰	90×90	偏心18	104	90	4	12	

NRV

030

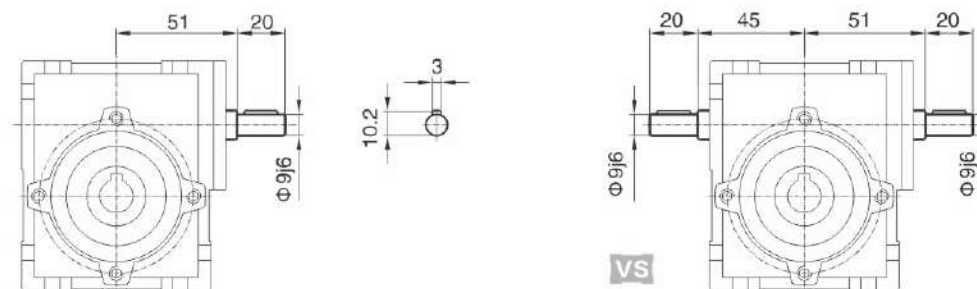

Output shaft 输出轴

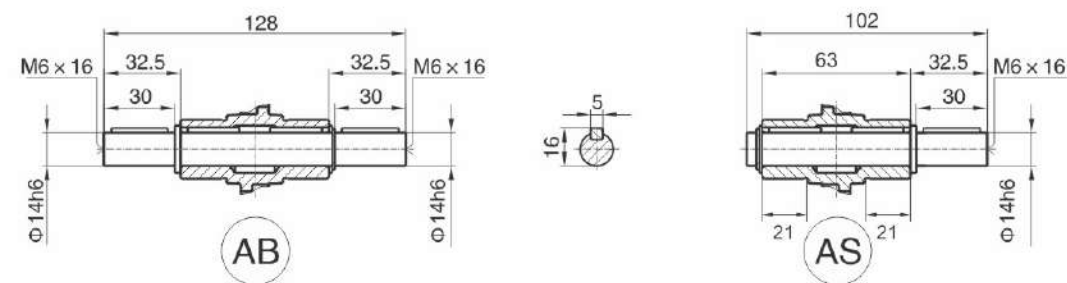

Output flange 输出法兰

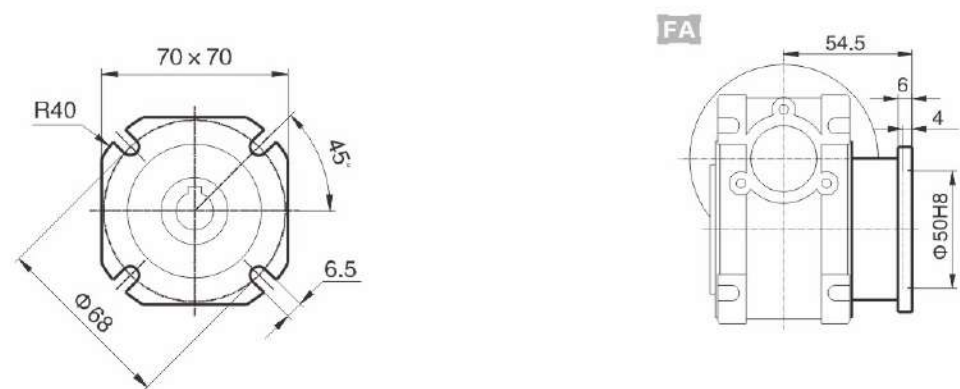

重量 Weight: 1.3kg

减速机外型尺寸 Dimensions

NMRV

040

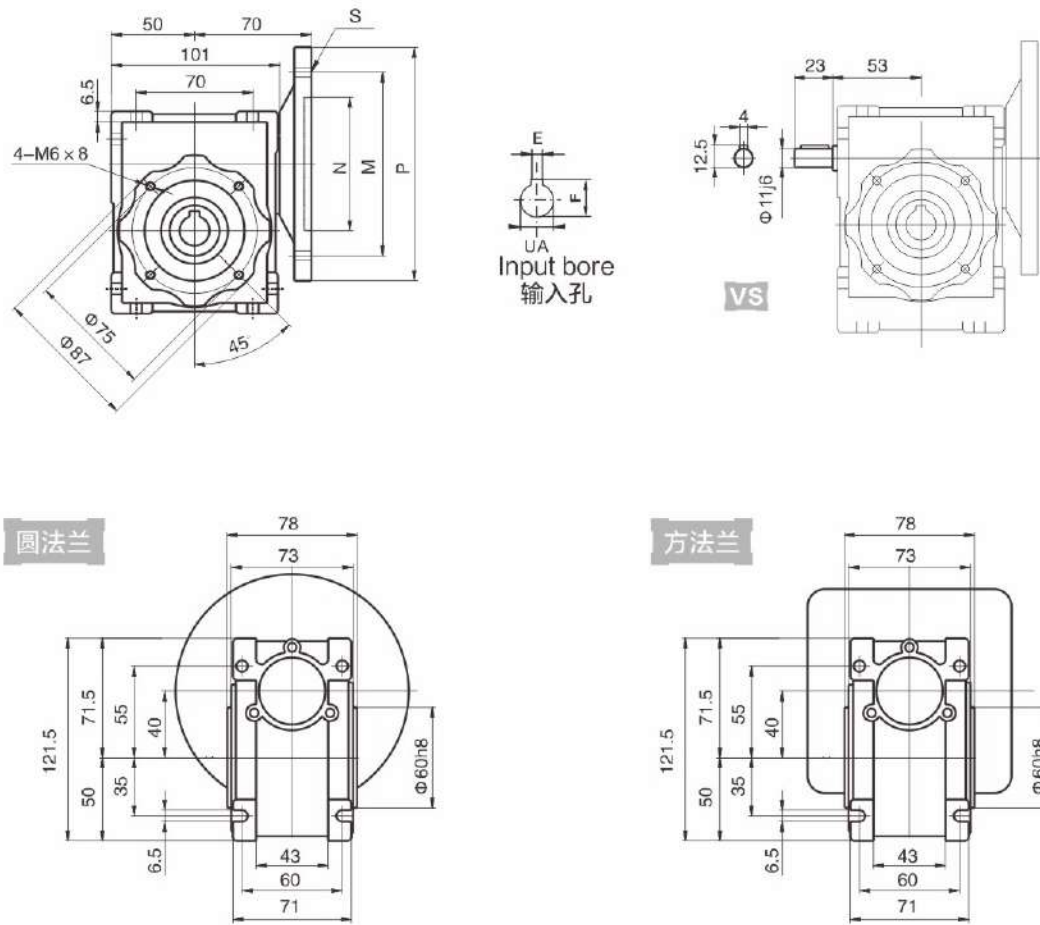

中心距: Center Distance A	法兰型式 Flange Type	电机法兰 Motor Flange					键槽 E	输入轴孔直径UA Input Shaft Hole Diameter
		法兰规格 PAM IEC	止口 N	对角螺丝孔距 M	法兰直径 P			
40	圆法兰	71B5	110	130	160	3、4、5	9、11、14	
		71B14	70	85	105			
		63B5	95	115	140			
		63B14	60	75	90			
		56B5	80	100	120			
中心距: Center Distance A	法兰型式 Flange Type	电机法兰 Motor Flange					键槽 E	输入轴孔直径UA Input Shaft Hole Diameter
		法兰规格 PAM IEC	止口 N	对角螺丝孔距 M	法兰边长 P			
40	方法兰	60x60	50	67	60	3、4、5	9、11、14	
		80x80	60、70、73	94	80			
		86x86	60、70、73	95(U型螺丝孔)	86			
		90x90	80、83	104(U型螺丝孔)	90			
		104x104	94、95	120(U型螺丝孔)	104			
	偏心方法兰	90x90	偏心18	104	90	4、5	12、15	
		104x104	偏心20	120	104			

NRV

040

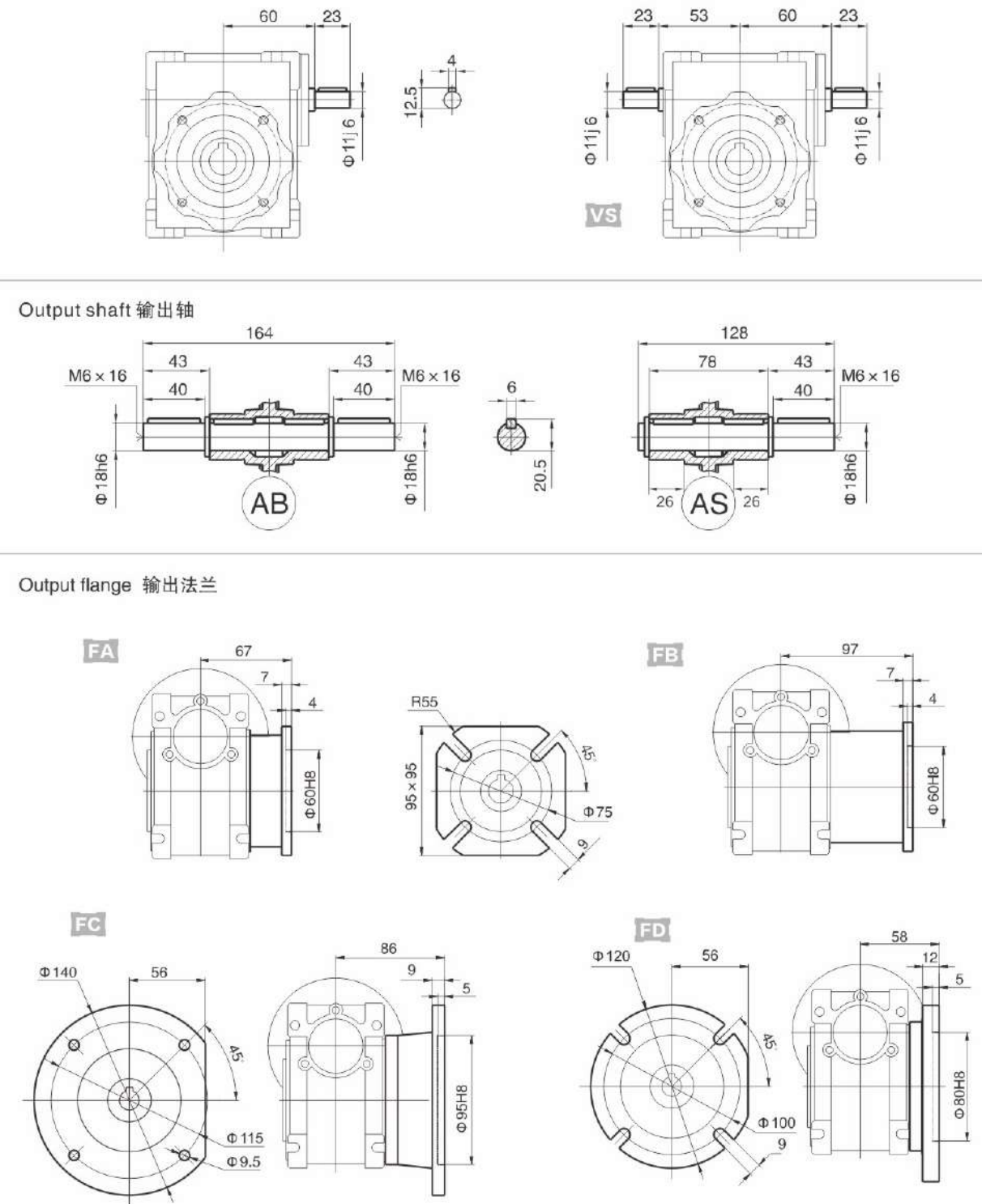

重量 Weight: 2.4kg

减速机外型尺寸 Dimensions

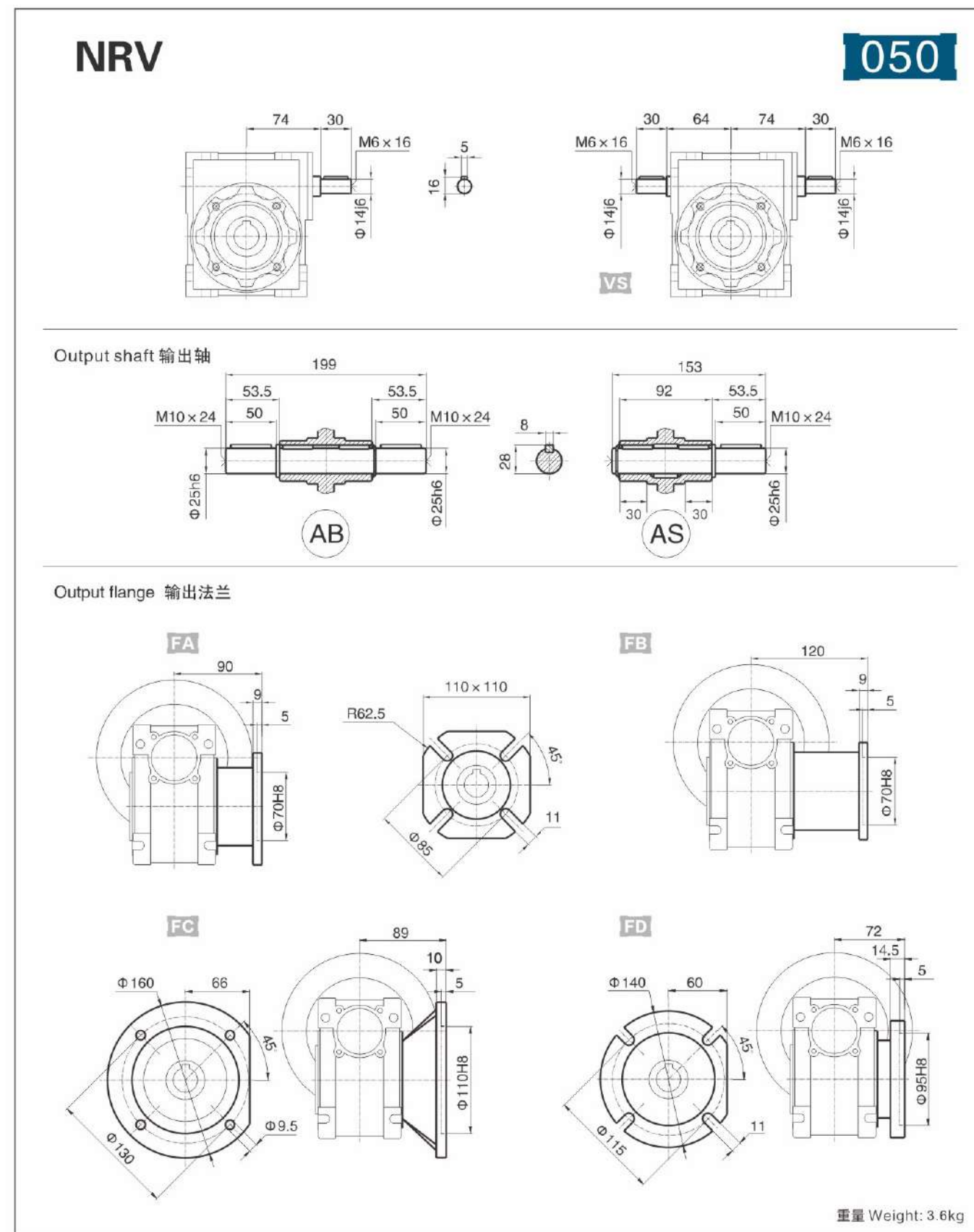
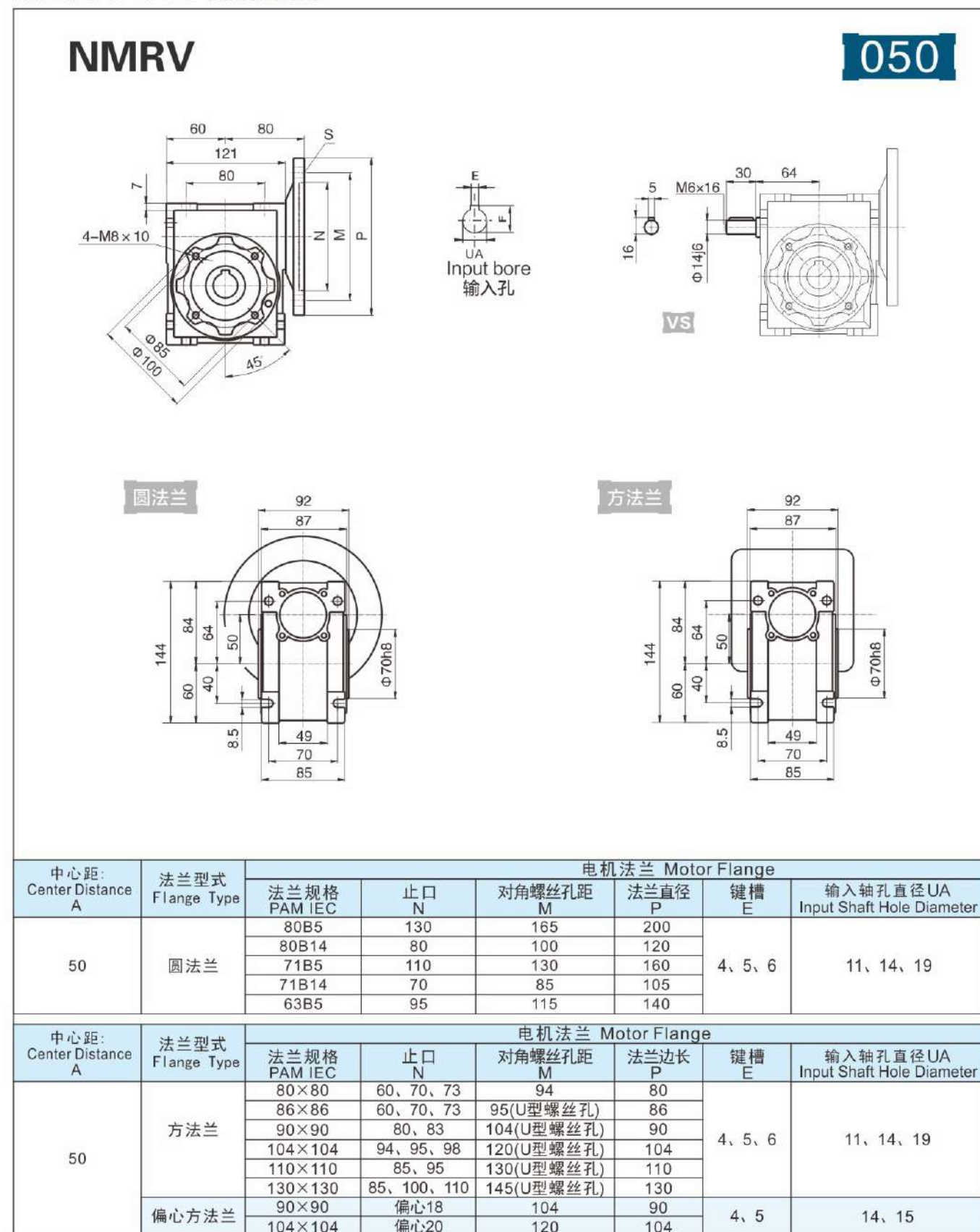

减速机外型尺寸 Dimensions

NMRV

063

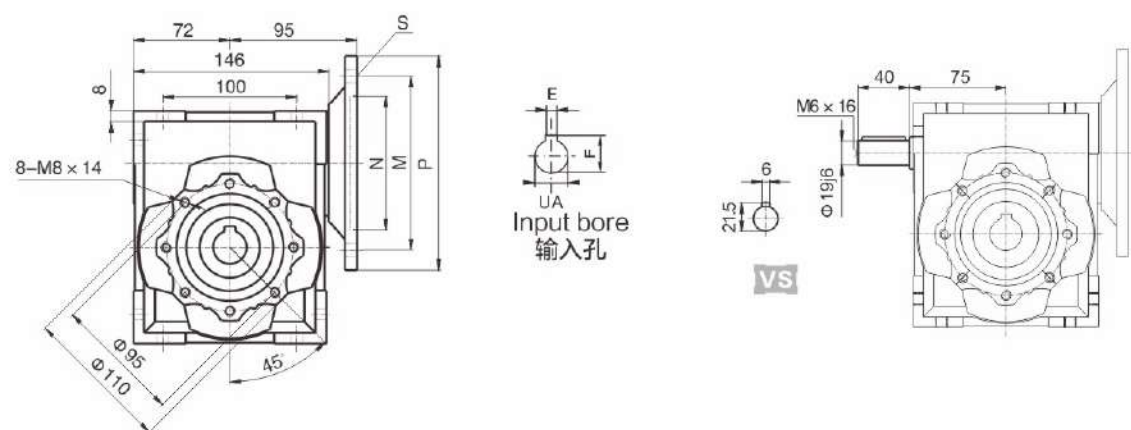

圆法兰

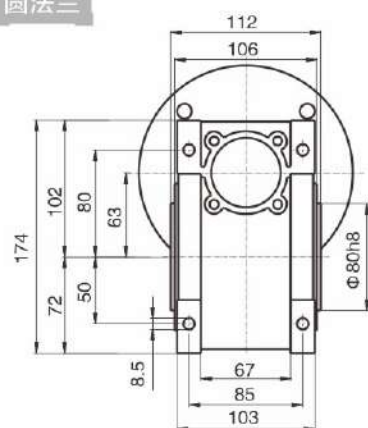

方法兰

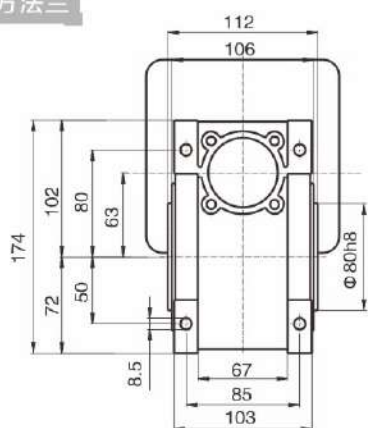

中心距: Center Distance A	法兰型式 Flange Type	电机法兰 Motor Flange					
		法兰规格 PAM IEC	止口 N	对角螺丝孔距 M	法兰直径 P	键槽 E	输入轴孔直径UA Input Shaft Hole Diameter
63	圆法兰	90B5	130	165	200	5、6、8	14、19、24
		90B14	95	115	140		
		80B5	130	165	200		
		80B14	80	100	120		
		71B5	110	130	160		
		71B14	70	85	105		
中心距: Center Distance A	法兰型式 Flange Type	电机法兰 Motor Flange					
		法兰规格 PAM IEC	止口 N	对角螺丝孔距 M	法兰边长 P	键槽 E	输入轴孔直径UA Input Shaft Hole Diameter
63	方法兰	86×86	73、80	95(U型螺丝孔)	86	5、6、8	14、19、22、24
		110×110	85、95	130(U型螺丝孔)	110		
		130×130	85、100、110	145(U型螺丝孔)	130		

NRV

063

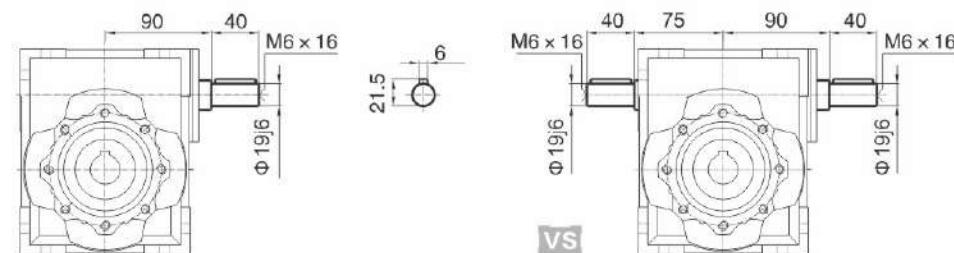

Output shaft
输出轴

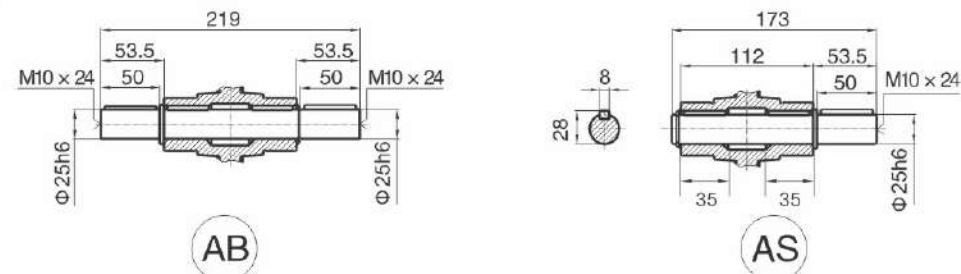

Output flange
输出法兰

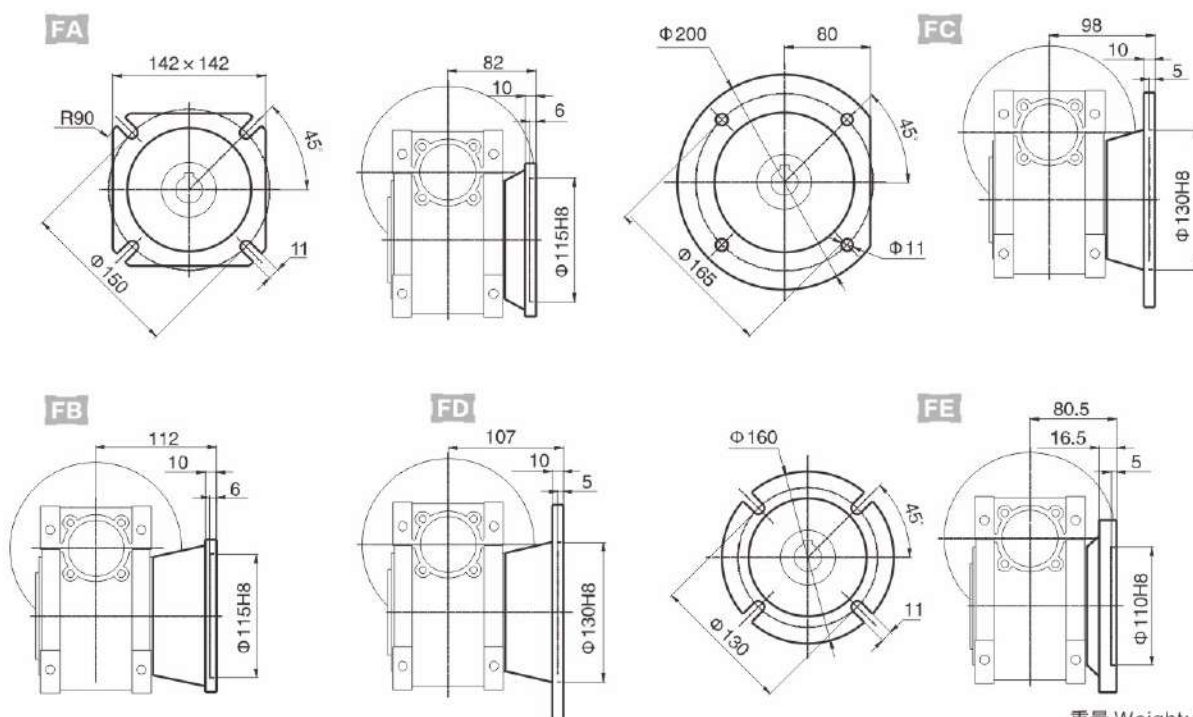

重量 Weight: 6.3kg

减速机外型尺寸 Dimensions

NMRV

110

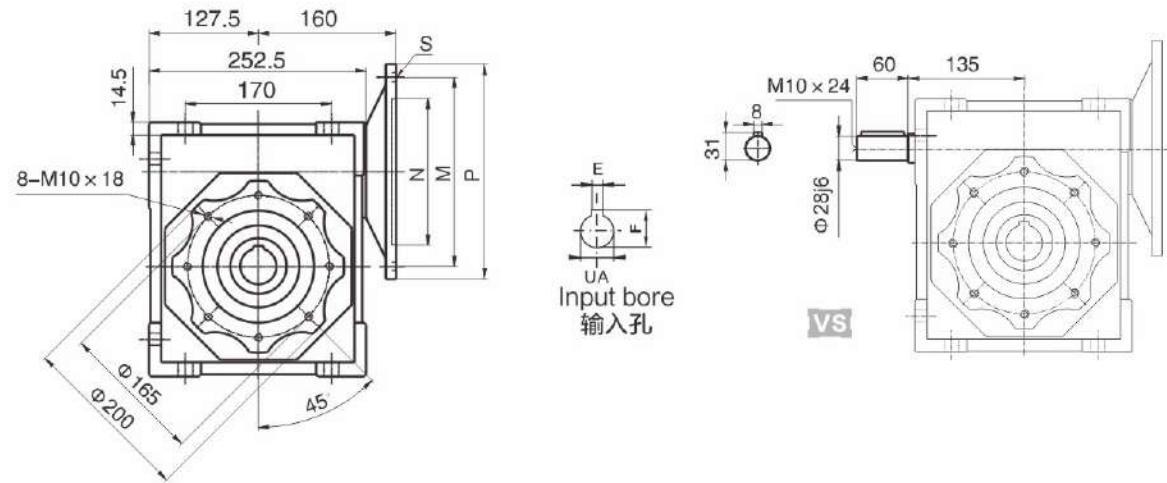

圆法兰

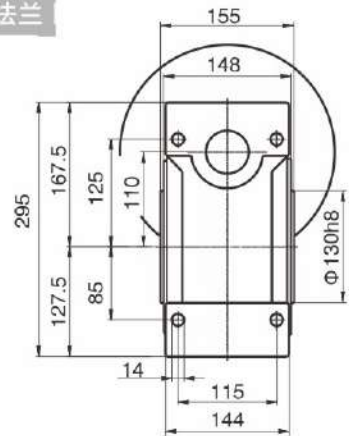

方法兰

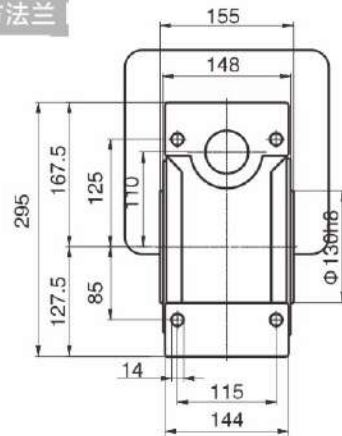

中心距: Center Distance A	法兰型式 Flange Type	电机法兰 Motor Flange					
		法兰规格 PAM IEC	止口 N	对角螺丝孔距 M	法兰直径 P	键槽 E	输入轴孔直径UA Input Shaft Hole Diameter
110	圆法兰	132B5	230	265	300	6, 8, 10	19, 24, 28, 38
		132B14	130	165	200		
		100/112B5	180	215	250		
		90B5	130	165	200		
		90B14	95	115	140		
		80B5	130	165	200		
中心距: Center Distance A	法兰型式 Flange Type	电机法兰 Motor Flange					
		法兰规格 PAM IEC	止口 N	对角螺丝孔距 M	法兰边长 P	键槽 E	输入轴孔直径UA Input Shaft Hole Diameter
110	方法兰	130x130	85, 100, 110	145(U型螺丝孔)	130	8, 10	22, 24, 28, 35, 38
		180x180	114.3	200	180		

NRV

110

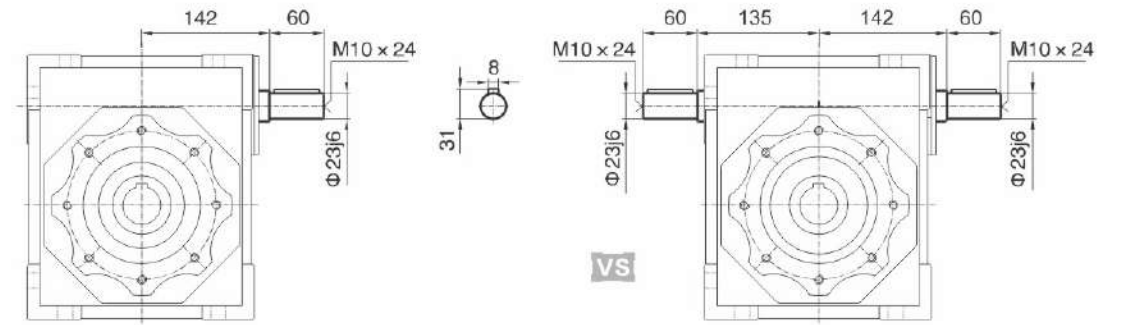

Output shaft 输出轴

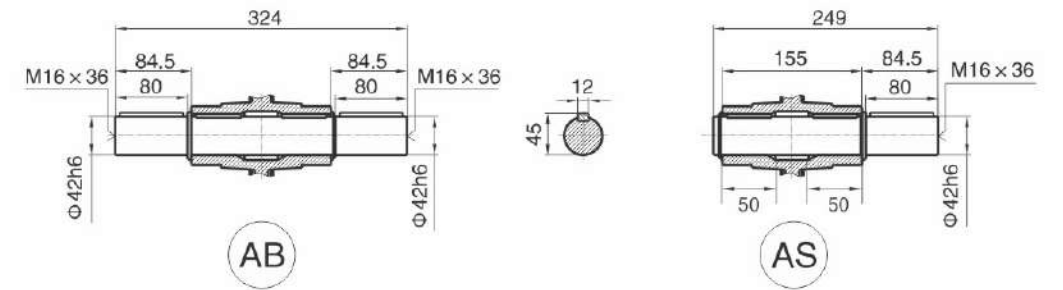

Output flange 输出法兰

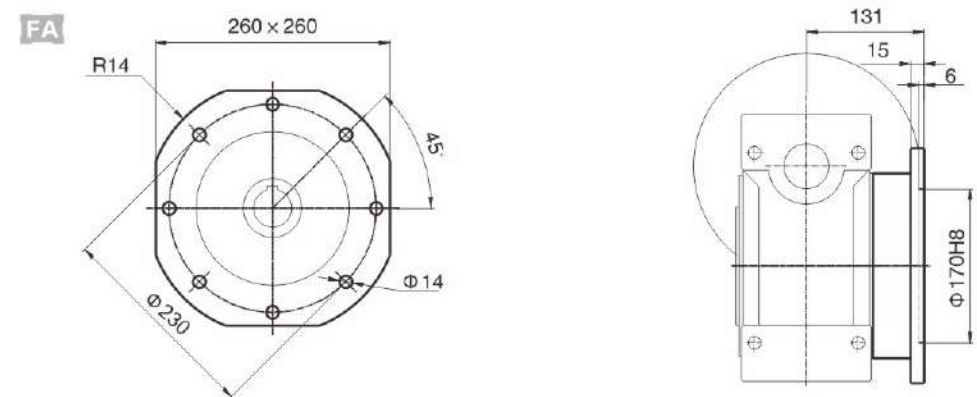

重量 Weight: 40kg

减速机外型尺寸 Dimensions

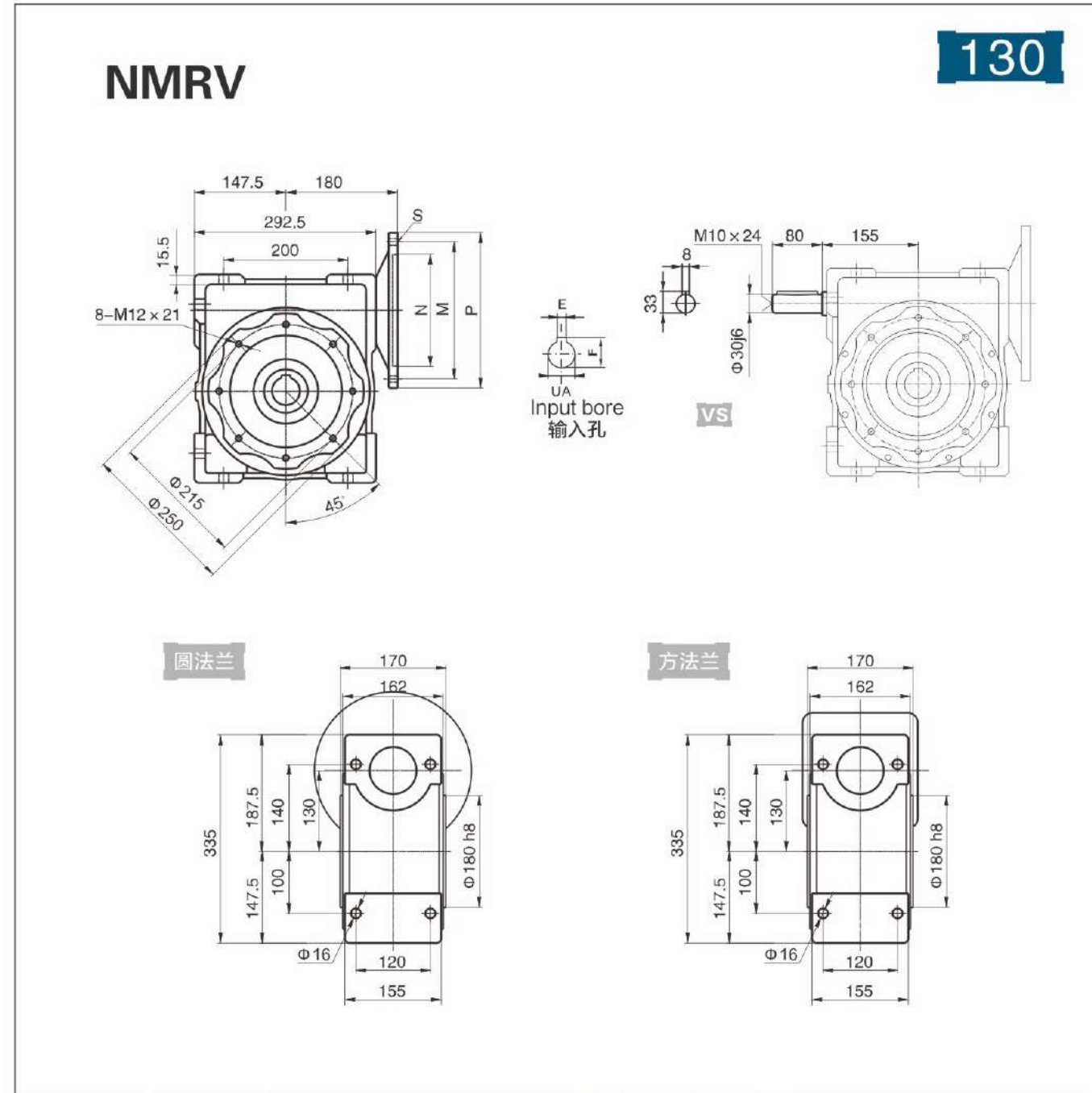

中心距: Center Distance A	法兰型式 Flange Type	电机法兰 Motor Flange					
		法兰规格 PAM IEC	止口 N	对角螺丝孔距 M	法兰直径 P	键槽 E	输入轴孔直径UA Input Shaft Hole Diameter
130	圆法兰	132B5	230	265	300	8、10	24、28、38
		132B14	130	165	200		
		100/112B5	180	215	250		
		90B5	130	165	200		
		90B14	95	115	140		
130	方法兰	180×180	114.3	200	180	8、10	22、24、28、35、38

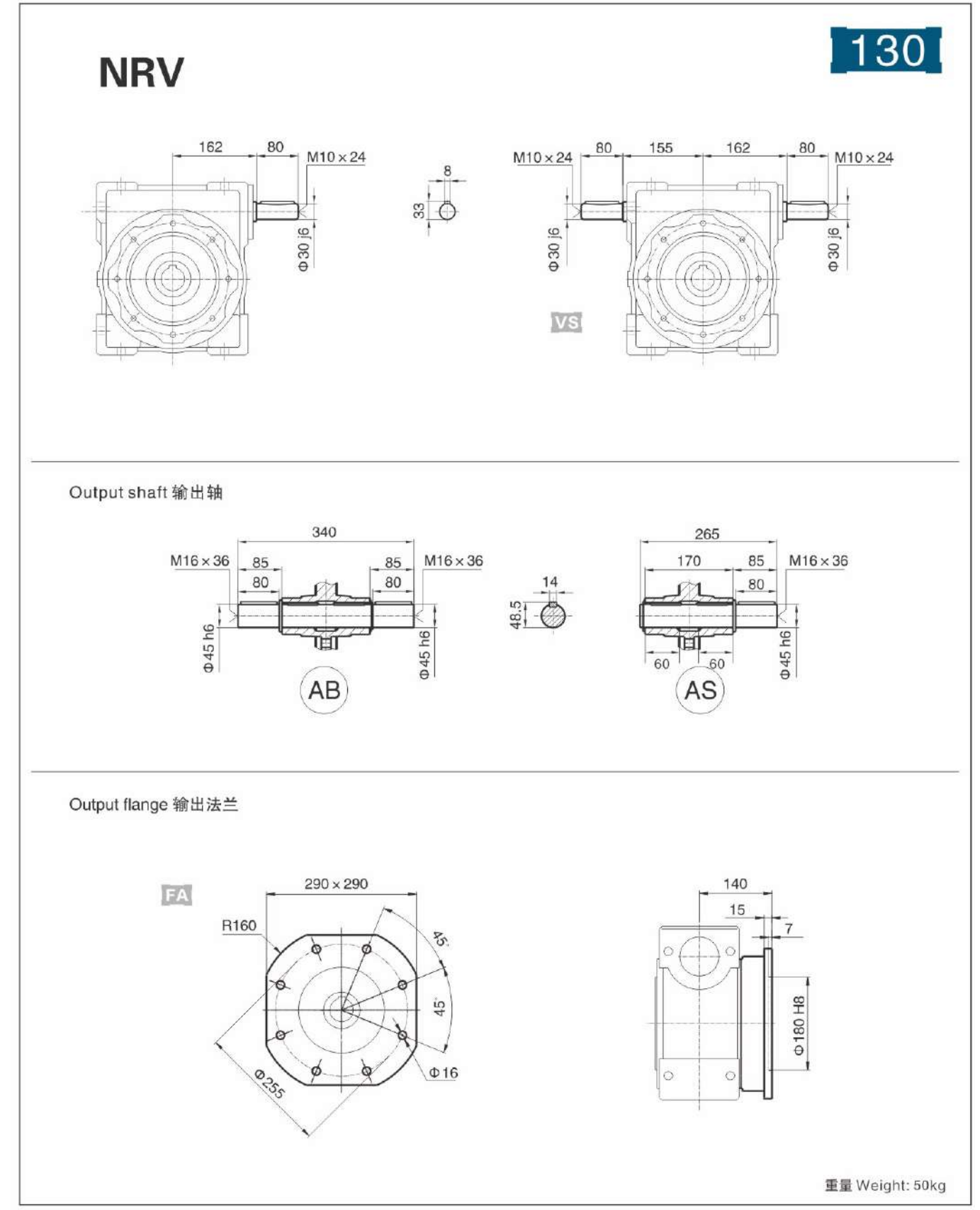

减速机外型尺寸 Dimensions

NMRV

150

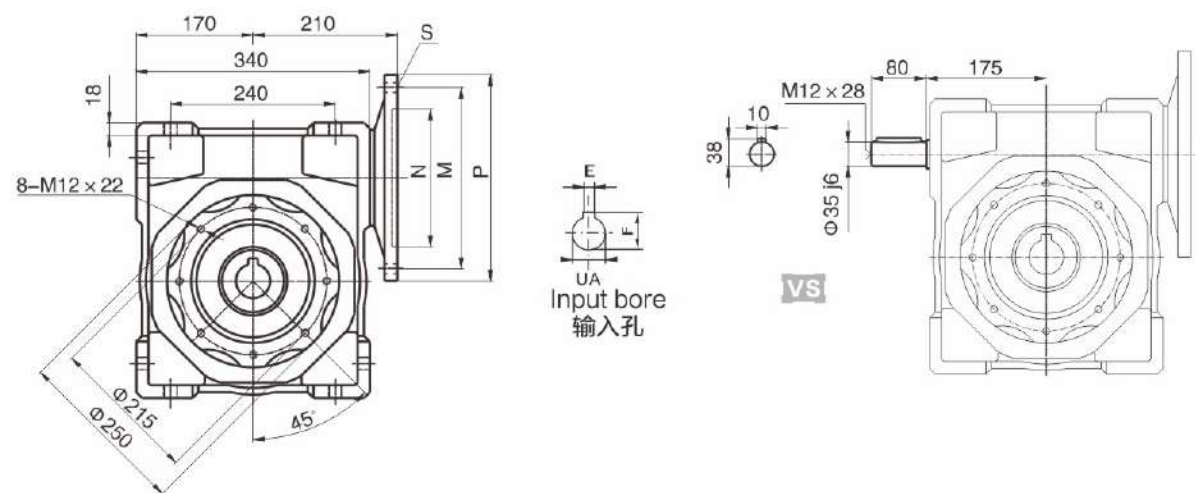

Input bore
输入孔

圆法兰

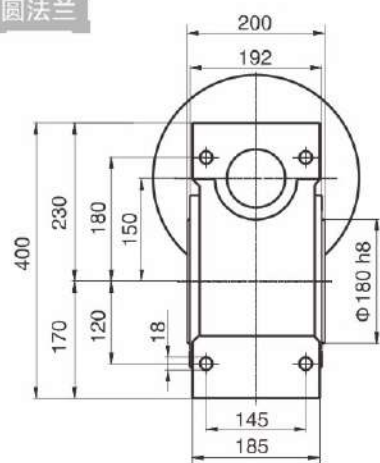

方法兰

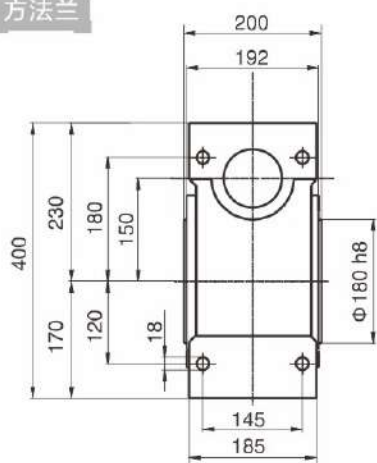

中心距 Center Distance A	法兰型式 Flange Type	电机法兰 Motor Flange					
		法兰规格 PAM IEC	止口 N	对角螺丝孔距 M	法兰直径 P	键槽 E	输入轴孔直径UA Input Shaft Hole Diameter
150	圆法兰	160B5	250	300	350	8、10、12	28、35、38、42
		132B5	230	265	300		
		132B14	130	165	200		
		100/112B5	180	215	250		
中心距 Center Distance A	法兰型式 Flange Type	电机法兰 Motor Flange					
		法兰规格 PAM IEC	止口 N	对角螺丝孔距 M	法兰边长 P	键槽 E	输入轴孔直径UA Input Shaft Hole Diameter
150	方法兰	180×180	114.3	200	180	8、10、12	28、35、38、42

NRV

150

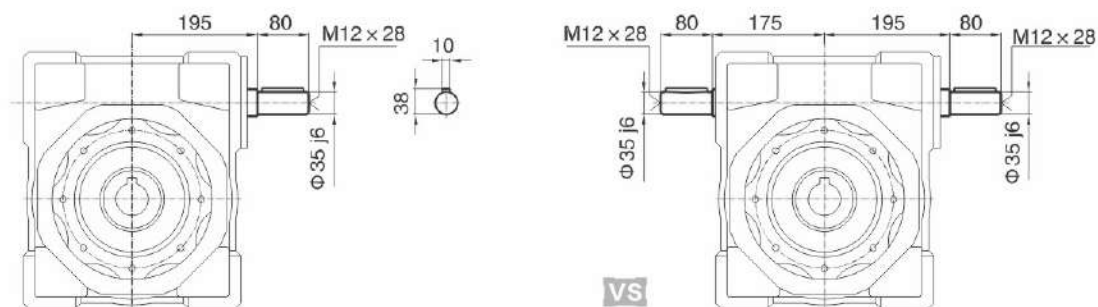

Output shaft 输出轴

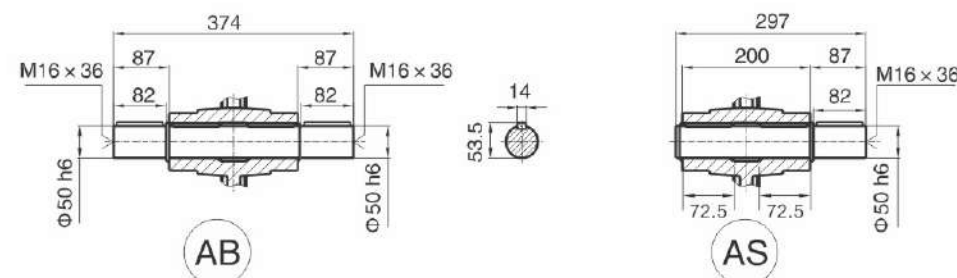

Output flange 输出法兰

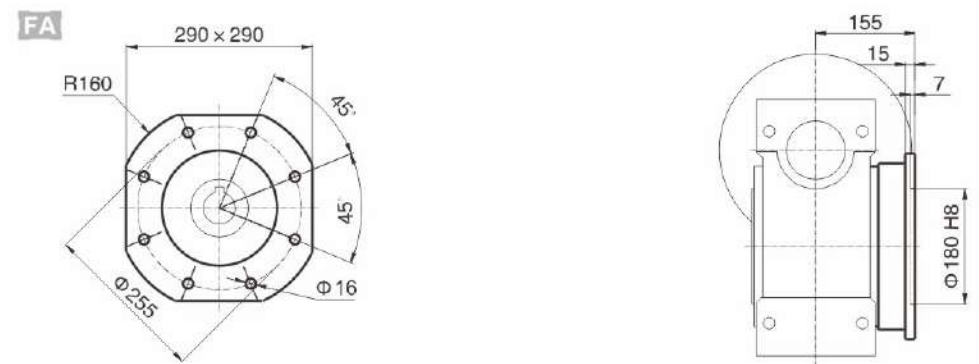

重量 Weight: 84kg

NMRV-NMRV

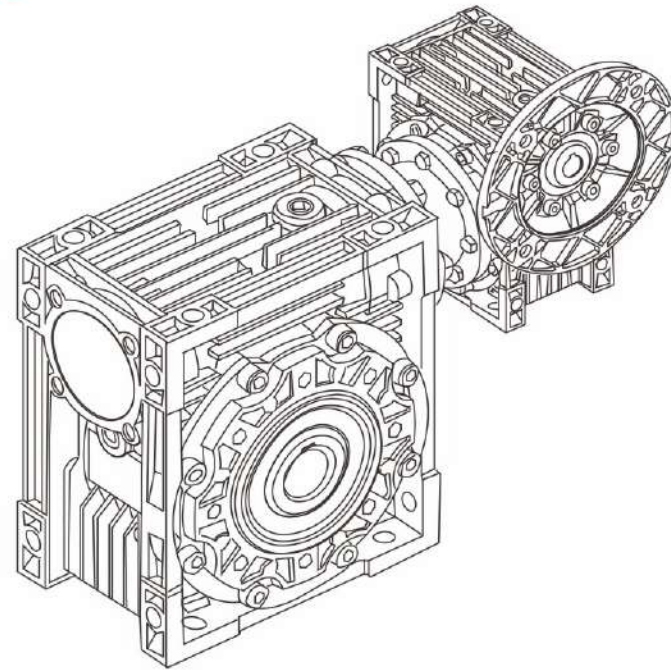

NMRV-NMRV

型号说明 Model notes

NMRV-063/130-600-VS-F1 (FA)-AS-80B5-0.75kW-AS1			
NMRV-NMRV	双蜗轮减速机 Combined worm geared motor		
NRV-NMRV	蜗轮减速机(配接输入轴) Worm gear speed reducer (Mounting input shaft)		
063/130	蜗轮减速机中心距 Center distance		
600	减速比 Reduction ratio		
VS	双向输入轴 Double input shaft	F1 (FA)	输出法兰位置及型号 Output flange
AS	单向输出轴 Single output shaft	AB	双向输出轴 Double output shaft
PAM	电机联接 Fitted for motor coupling	80B5	电机机座号和安装结构形式 Motor mounting facility
0.75kW	电机功率 Electric motor power	As1	安装方位 Mounting position

NMRV-NMRV安装方式 Mounting positions

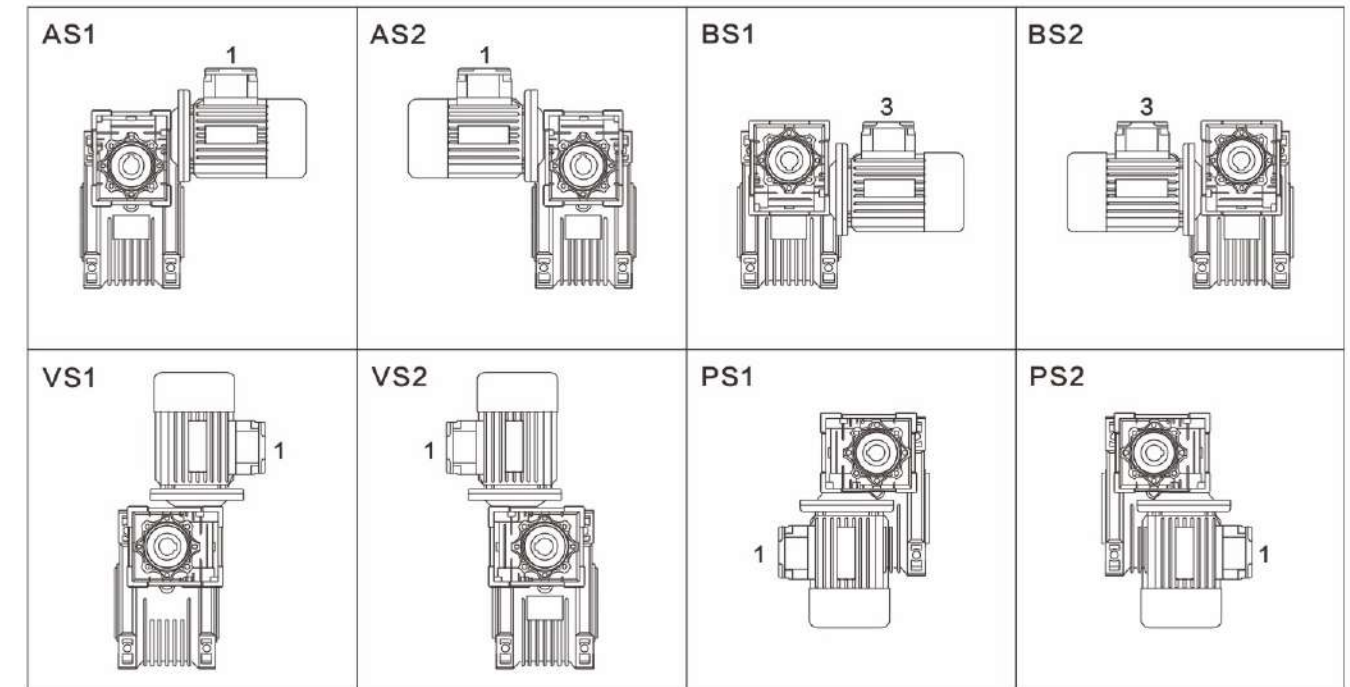

法兰输出 Output flange F-FL

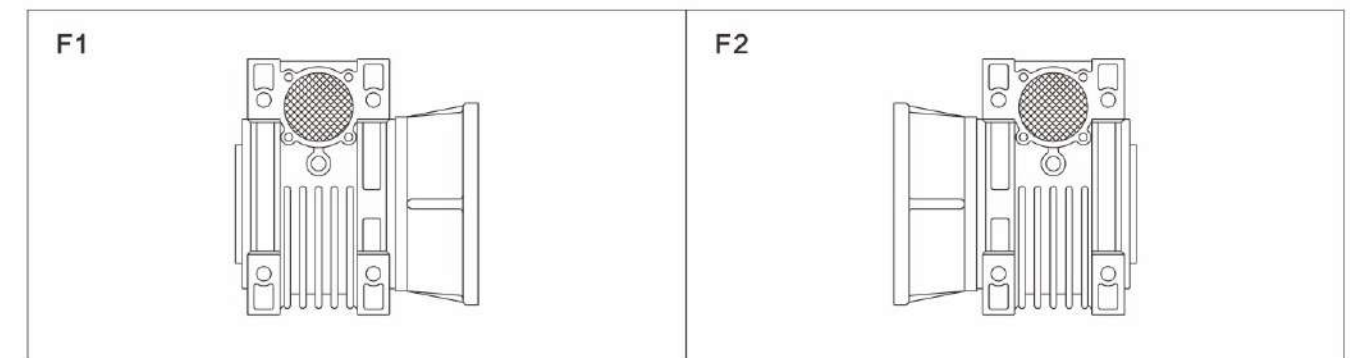

电机接线盒方位 Position of terminal box

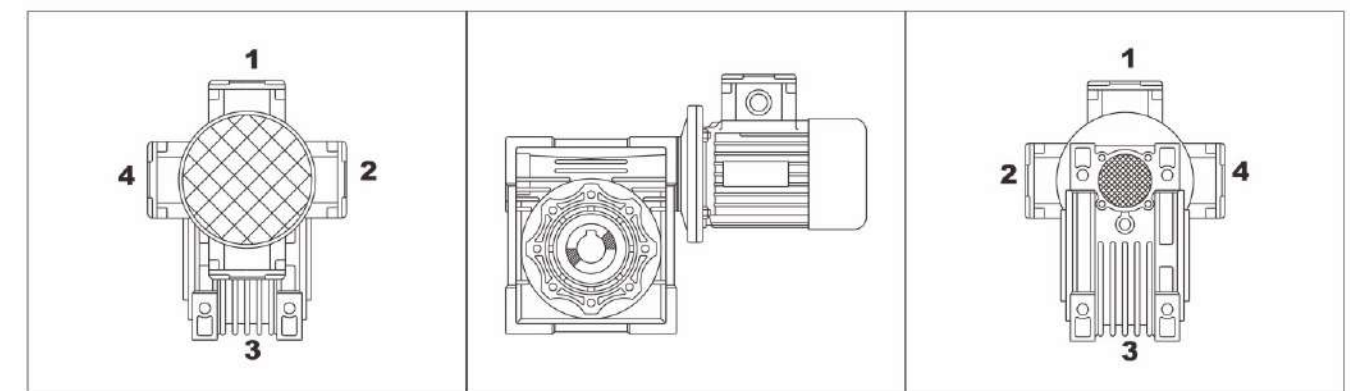

选型参数 Parameter selections

双级减速机(法兰输入, 输入转速1400r/min)/(配4极电机)

Double step reducer(flange input, input speed is 1400r/min)/(matched with 4 poles motor)

组合 机型 Model	输出 转速 N ₂ (r/min)	输出 转矩 M ₂ (N.m)	总 传动比 i	高速级 传动比 i ₁	低速级 传动比 i ₂	输出轴 径向力 kN	使用 系数 f.s.
0.06kw							
25/30	14	25	100	10	10	1.62	1.3
	9.3	32	150	10	15	1.83	0.9
	7.0	41	200	10	20	1.83	0.7
	5.6	44	250	10	25	1.83	0.8
25/40	4.7	59	300	10	30	3.49	1.2
	3.5	71	400	10	40	3.49	0.9
	2.8	82	500	20	25	3.49	0.7
	2.3	101	600	20	30	3.49	0.6
	1.9	116	750	25	30	3.49	0.5
	1.6	143	900	30	30	3.49	0.5
	1.2	171	1200	30	40	3.49	0.4
	0.9	197	1500	50	30	3.49	0.3
	0.8	217	1800	60	30	3.49	0.3
	0.6	268	2400	60	40	3.49	0.2
0.5	324	3000	60	50	3.49	0.2	
0.4	294	4000	50	80	3.49	0.1	
0.3	356	5000	50	100	3.49	0.1	
30/40	4.7	57	300	10	30	3.49	1.3
	3.5	70	400	10	40	3.49	0.9
	2.8	96	500	20	25	3.49	0.6
	2.3	104	600	20	30	3.49	0.7
	1.9	121	750	25	30	3.49	0.6
	1.6	139	900	30	30	3.49	0.5
	1.2	166	1200	30	40	3.49	0.4
	0.9	196	1500	50	30	3.49	0.4
	0.8	218	1800	60	30	3.49	0.3
	0.58	261	2400	60	40	3.49	0.2
	0.4	300	3200	80	40	3.49	0.2
	0.4	279	4000	50	80	3.49	0.1
	0.28	338	5000	50	100	3.49	0.1
	30/50	1.6	141	900	30	30	4.84
1.2		169	1200	30	40	4.84	0.7
0.93		199	1500	50	30	4.84	0.7
0.78		222	1800	60	30	4.84	0.7
0.6		266	2400	60	40	4.84	0.5
0.5		307	3000	60	50	4.84	0.4
0.35		288	4000	50	80	4.84	0.3
0.29		311	4800	60	80	4.84	0.3
30/63	0.9	203	1500	30	50	6.27	1.1
	0.78	225	1800	30	60	6.27	0.9
	0.58	276	2400	60	40	6.27	0.8
	0.47	319	3000	60	50	6.27	0.7
	0.35	306	4000	50	80	6.27	0.6
0.28	360	5000	50	100	6.27	0.4	

组合 机型 Model	输出 转速 N ₂ (r/min)	输出 转矩 M ₂ (N.m)	总 传动比 i	高速级 传动比 i ₁	低速级 传动比 i ₂	输出轴 径向力 kN	使用 系数 f.s.	
0.06kw								
40/75	0.6	330	2400	60	40	7.38	1.1	
	0.47	377	3000	60	50	7.38	0.8	
	0.35	355	4000	50	80	7.38	0.7	
	0.28	419	5000	50	100	7.38	0.5	
	0.28	419	5000	50	100	7.38	0.5	
40/90	0.5	405	3000	60	50	8.18	1.4	
	0.35	365	4000	50	80	8.18	1.3	
	0.28	431	5000	50	100	8.18	1.0	
	0.28	431	5000	50	100	8.18	1.0	
0.09kw								
25/30	14	37	100	10	10	1.62	0.8	
	9.3	49	150	10	15	1.83	0.6	
	7.0	62	200	10	20	1.83	0.5	
	5.6	66	250	10	25	1.83	0.5	
	4.7	75	300	10	30	1.83	0.4	
	3.5	107	400	10	40	1.83	0.3	
	2.8	115	500	20	25	1.83	0.2	
	2.3	135	600	20	30	1.83	0.2	
	1.9	151	750	25	30	1.83	0.2	
	1.6	178	900	30	30	1.83	0.2	
30/40	1.2	212	1200	30	40	1.83	0.1	
	0.9	247	1500	50	30	1.83	0.1	
	0.78	304	1800	60	30	1.83	0.1	
	0.58	340	2400	60	40	1.83	0.1	
	0.47	405	3000	60	50	1.83	0.1	
	4.7	88	300	10	30	3.49	0.8	
	3.5	107	400	10	40	4.84	1.2	
	2.8	123	500	10	50	4.84	1.0	
	2.3	159	600	20	30	4.84	0.9	
	1.9	185	750	25	30	4.84	0.8	
	1.6	212	900	30	30	4.84	0.7	
	30/63	1.6	200	900	15	60	6.27	1.0
		1.2	263	1200	30	40	6.27	0.9
		0.93	305	1500	30	50	6.27	0.7
0.78		359	1500	50	30	7.38	1.1	
40/75	0.78	404	1800	60	30	7.38	1.0	
	0.58	496	2400	60	40	7.38	0.7	
	0.58	496	2400	60	40	7.38	0.7	
40/90	0.5	608	3000	60	50	8.18	0.9	
	0.35	548	4000	50	80	8.18	0.8	
	0.35	548	4000	50	80	8.18	0.8	
0.12kw								
30/50	4.7	118	300	10	30	4.84	1.2	
	3.5	142	400	10	40	4.84	0.9	
	2.8	164	500	10	50	4.84	0.7	
30/63	2.8	171	500	10	50	6.27	1.3	
	2.3	208	600	15	40	6.27	1.1	
	1.9	241	750	15	50	6.27	0.9	

组合 机型 Model	输出 转速 N ₂ (r/min)	输出 转矩 M ₂ (N.m)	总 传动比 i	高速级 传动比 i ₁	低速级 传动比 i ₂	输出轴 径向力 kN	使用 系数 f.s.
0.12kw							
40/75	1.6	324	900	30	30	7.38	1.2
	1.2	399	1200	30	40	7.38	0.9
40/90	0.78	546	1800	30	60	8.18	0.9
	0.58	695	2400	60	40	8.18	0.9
50/110	0.5	883	3000	60	50	10.32	1.2
	0.35	784	4000	50	80	10.32	1.0
	0.28	928	5000	50	100	10.32	0.8
0.18kw							
30/63	3.5	221	400	10	40	6.27	1.0
	2.8	257	500	10	50	6.27	0.8
40/75	2.3	362	600	20	30	7.38	1.1
	1.9	435	750	25	30	7.38	0.9
	1.6	487	900	30	30	7.38	0.8
40/90	1.2	629	1200	30	40	8.18	1.0
	0.93	735	1500	30	50	8.18	0.8
50/110	0.8	860	1800	60	30	10.32	1.5
	0.58	1113	2400	60	40	10.32	1.1
0.25kw							
30/63	3.5	159	400	10	40	6.27	1.4
	2.8	185	500	10	50	6.27	1.2
40/75	3.5	336	400	10	40	7.38	1.1
	2.8	384	500	10	50	7.38	0.8
40/90	2.3	511	600	15	40	8.18	1.2
	1.9	598	750	15	50	8.18	0.9
	1.6	667	900	15	60	8.18	0.8
50/110	1.2	943	1200	30	40	10.32	1.3
	0.93	1064	1500	50	30	10.32	1.2
	0.78	1195	1800	60	30	10.32	1.1
63/130	0.6	1624	2400	60	40	13.5	1.0
	0.47	1935	3000	60	50	13.5	0.8
	0.35	2046	4000	50	80	13.5	0.6
	0.28	2430	5000	50	100	13.5	0.5
63/150	0.8	1199	1800	60	30	18	1.8
	0.8	1199	1800	60	30	18	1.8
	0.6	1446	2400	60	40	18	1.8
	0.5	1713	3000	60	50	18	1.4
	0.4	2026	4000	50	80	18	0.9
0.3	2251	5000	50	100	18	0.7	
0.37kw							
40/175	4.7	405	300	10	30	7.38	1.0
	3.5	498	400	10	40	7.38	0.7
40/90	4.7	401	300	7.5	40	8.18	1.5
	3.5	523	400	10	40	8.18	1.2
	2.8	611	500	10	50	8.18	0.9
	2.3	757	600	15	40	8.18	0.8
50/110	1.9	949	750	25	30	10.32	1.3
	1.6	1079	900	30	30	10.32	1.2
	1.2	1396	1200	30	40	10.32	0.8
63/130	0.9	1674	1500	50	30	13.5	1.1

组合 机型 Model	输出 转速 N ₂ (r/min)	输出 转矩 M ₂ (N.m)	总 传动比 i	高速级 传动比 i ₁	低速级 传动比 i ₂	输出轴 径向力 kN	使用 系数 f.s.
0.37kw							
63/130	0.78	1887	1800	60	30	13.5	0.9
63/150	0.78	1774	1800	60	30	18	1.2
	0.6	2141	2400	60	40	18	1.2
	0.5	2535	3000	60	50	18	0.9
0.55kw							
50/110	4.7	638	300	10	30	10.32	2.0
	3.5	826	400	10	40	10.32	1.4
	2.8	984	500	10	50	10.32	1.1
	2.3	1181	600	15	40	10.32	1.0
	1.9	1411	750	25	30	10.32	0.9
63/130	2.8	995	500	10	50	13.5	1.6
	1.9	1471	750	25	30	13.5	1.2
	1.2	2132	1200	30	40	13.5	0.8
63/150	0.78	2637	1800	60	30	18	0.8
	0.6	3182	2400	60	40	18	0.8
0.75kw							
50/110	4.7	871	300	10	30	10.32	1.5
	3.5	1126	400	10	40	10.32	1.1
63/130	2.8	1357	500	10	50	13.5	1.1
	2.3	1631	600	15	40	13.5	1.0
	1.9	2005	750	25	30	13.5	0.9
	1.6	2283	900	30	30	13.5	0.8
63/150	2.8	1290	500	10	50	18	1.8
	2.3	1529	600	15	40	18	1.7
	1.9	1783	750	25	30	18	1.3
	1.6	2215	900	30	30	18	0.9
	1.2	2680	1200	30	40	18	1.0
1.1kw							
63/130	4.7	1312	300	10	30	13.5	1.3
	3.5	1671	400	10	40	13.5	1.0
	2.8	1991	500	10	50	13.5	0.8
63/150	9.3	752	150	10	15	18	3.1
	7.0	966	200	10	20	18	2.4
	5.6	1175	250	10	25	18	1.7
	4.7	1364	300	10	30	18	1.7
	3.5	1619	400	10	40	18	1.6
	2.8	1893	500	10	50	18	1.2
	2.3	2242	600	15	40	18	1.2
1.9	2616	750	25	30	18	0.9	
1.5kw							
63/130	4.7	1789	30				

双级减速机(轴伸输入, 输入转速1400r/min)

Double step reducer (shaft extend input, input speed is 1400r/min)

机型代号 Model	输入轴 功率 kw	输出转速 N ₂ (r/min)	输出转矩 M ₂ (N.m)	传动比 i	输出轴 径向力 kN	输出轴 径向力 kN
30/40	0.1	4.7	73	300	3.49	0.21
	0.1	3.5	65	400	3.49	0.21
	0.08	2.8	61	500	3.49	0.21
	0.06	2.3	73	600	3.49	0.21
	0.04	1.9	73	750	3.49	0.21
	0.03	0.6	73	900	3.49	0.21
	0.02	1.2	65	1200	3.49	0.21
	0.02	0.9	73	1500	3.49	0.21
	0.02	0.8	73	1800	3.49	0.21
	0.01	0.58	65	2400	3.49	0.21
0.01	0.4	65	3200	3.49	0.21	
0.01	0.35	33	4000	3.49	0.21	
0.01	0.28	29	5000	3.49	0.21	
30/50	0.15	4.7	145	300	4.84	0.21
	0.1	3.5	124	400	4.84	0.21
	0.1	2.8	120	500	4.84	0.21
	0.1	2.3	145	600	4.84	0.21
	0.1	1.9	145	750	4.84	0.21
	0.1	1.6	145	900	4.84	0.21
	0.08	1.2	124	1200	4.84	0.21
	0.06	0.93	145	1500	4.84	0.21
	0.04	0.78	145	1800	4.84	0.21
	0.03	0.6	124	2400	4.84	0.21
0.02	0.5	120	3000	4.84	0.21	
0.02	0.35	82	4000	4.84	0.21	
0.02	0.29	82	4800	4.84	0.21	
30/63	0.24	4.7	230	300	6.27	0.21
	0.2	3.5	230	400	6.27	0.21
	0.2	2.8	216	500	6.27	0.21
	0.13	2.3	230	600	6.27	0.21
	0.11	1.9	216	750	6.27	0.21
	0.1	1.6	198	900	6.27	0.21
	0.1	1.2	230	1200	6.27	0.21
	0.1	0.93	216	1500	6.27	0.21
	0.1	0.78	198	1800	6.27	0.21
	0.1	0.58	230	2400	6.27	0.21
0.08	0.47	216	3000	6.27	0.21	
0.06	0.35	172	4000	6.27	0.21	
0.04	0.28	150	5000	6.27	0.21	
40/75	0.4	4.7	390	300	7.38	0.35
	0.3	3.5	360	400	7.38	0.35
	0.21	2.8	320	500	7.38	0.35
	0.2	2.3	390	600	7.38	0.35
	0.2	1.9	390	750	7.38	0.35
	0.14	1.6	390	900	7.38	0.35
	0.11	1.2	360	1200	7.38	0.35
	0.1	0.93	390	1500	7.38	0.35
	0.1	0.78	390	1800	7.38	0.35
	0.1	0.58	360	2400	7.38	0.35
0.1	0.47	320	3000	7.38	0.35	
0.08	0.35	250	4000	7.38	0.35	
0.06	0.28	230	5000	7.38	0.35	

机型代号 Model	输入轴 功率 kw	输出转速 N ₂ (r/min)	输出转矩 M ₂ (N.m)	传动比 i	输出轴 径向力 kN	输出轴 径向力 kN
40/90	0.6	4.7	610	300	8.18	0.35
	0.43	3.5	610	400	8.18	0.35
	0.34	2.8	560	500	8.18	0.35
	0.3	2.3	610	600	8.18	0.35
	0.23	1.9	560	750	8.18	0.35
	0.2	1.6	505	900	8.18	0.35
	0.3	1.2	610	1200	8.18	0.35
	0.14	0.93	560	1500	8.18	0.35
	0.11	0.78	505	1800	8.18	0.35
	0.11	0.58	610	2400	8.18	0.35
0.1	0.47	560	3000	8.18	0.35	
0.1	0.35	460	4000	8.18	0.35	
0.1	0.28	410	5000	8.18	0.35	
50/110	1.1	4.7	1265	300	10.32	0.49
	0.8	3.5	1185	400	10.32	0.49
	0.61	2.8	1100	500	10.32	0.49
	0.6	2.3	1185	600	10.32	0.49
	0.5	1.9	1265	750	10.32	0.49
	0.43	1.6	1265	900	10.32	0.49
	0.31	1.2	1186	1200	10.32	0.49
	0.3	0.93	1265	1500	10.32	0.49
	0.3	0.78	1265	1800	10.32	0.49
	0.2	0.58	1185	2400	10.32	0.49
0.15	0.47	1100	3000	10.32	0.49	
0.13	0.35	819	4000	10.32	0.49	
0.1	0.28	746	5000	10.32	0.49	
63/130	0.8	2.3	1650	600	13.5	0.7
	0.7	1.9	1760	750	13.5	0.7
	0.6	1.6	1760	900	13.5	0.7
	0.4	1.2	1650	1200	13.5	0.7
	0.4	0.93	1760	1500	13.5	0.7
	0.4	0.93	1760	1500	13.5	0.7
	0.3	0.78	1760	1800	13.5	0.7
	0.3	0.58	1650	2400	13.5	0.7
	0.2	0.47	1550	3000	13.5	0.7
	0.1	0.35	1220	4000	13.5	0.7
0.1	0.28	1100	5000	13.5	0.7	
63/150	3.4	9.3	2340	150	18	0.7
	2.7	7.0	2340	200	18	0.7
	1.9	5.6	2050	250	18	0.7
	1.9	4.7	2340	300	18	0.7
	1.8	3.5	2670	400	18	0.7
	1.4	2.8	2330	500	18	0.7
	1.3	2.3	2670	600	18	0.7
	1.0	1.9	2330	750	18	0.7
	0.7	1.6	2100	900	18	0.7
	0.7	1.2	2670	1200	18	0.7
0.4	0.8	2100	1800	18	0.7	
0.5	0.6	2670	2400	18	0.7	
0.3	0.5	2330	3000	18	0.7	
0.2	0.4	1880	4000	18	0.7	
0.2	0.3	1650	5000	18	0.7	

NMRV-NMRV外型尺寸 Dimensions

NMRV025-NMRV030

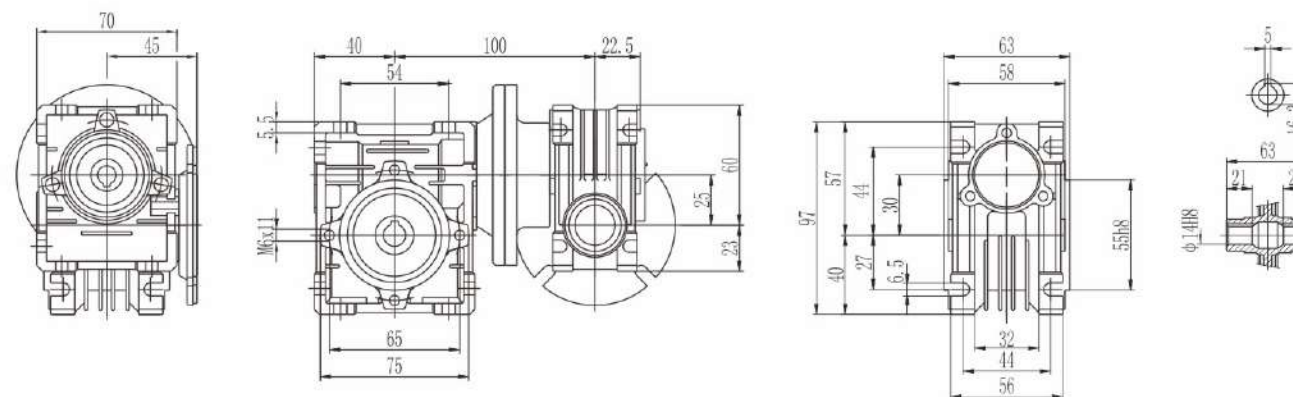

NMRV025-NMRV040

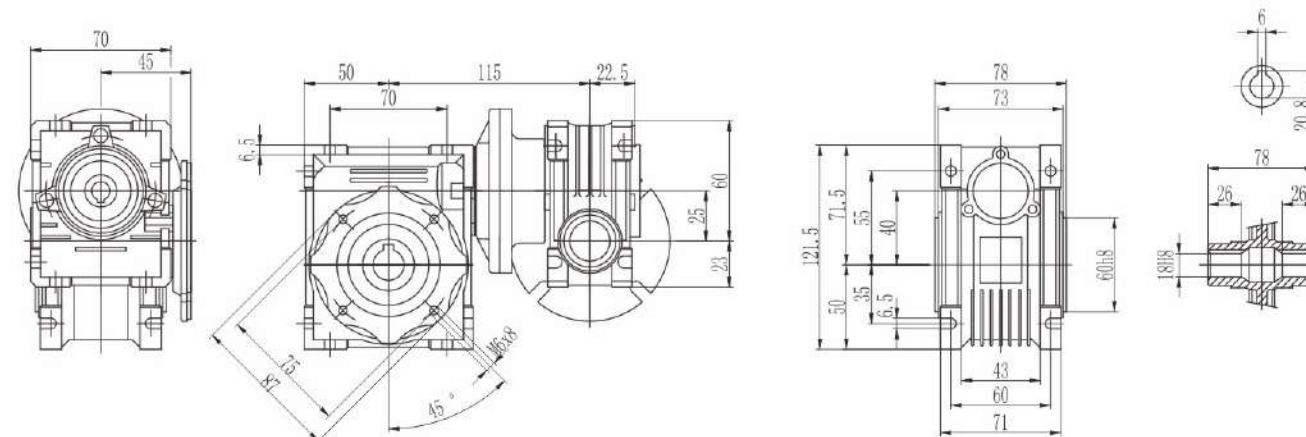

NMRV030-NMRV040

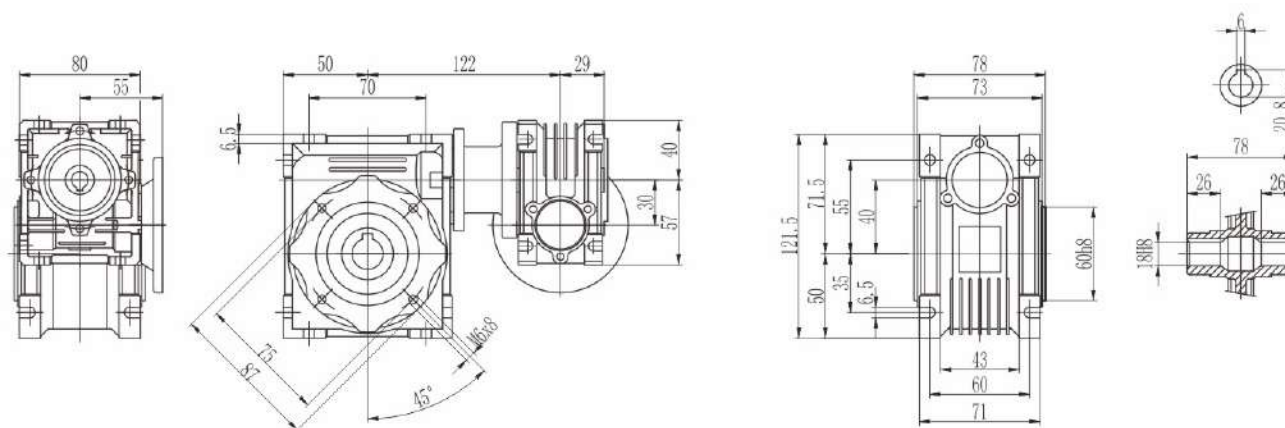

NMRV-NMRV外型尺寸 Dimensions

NMRV030-NMRV050

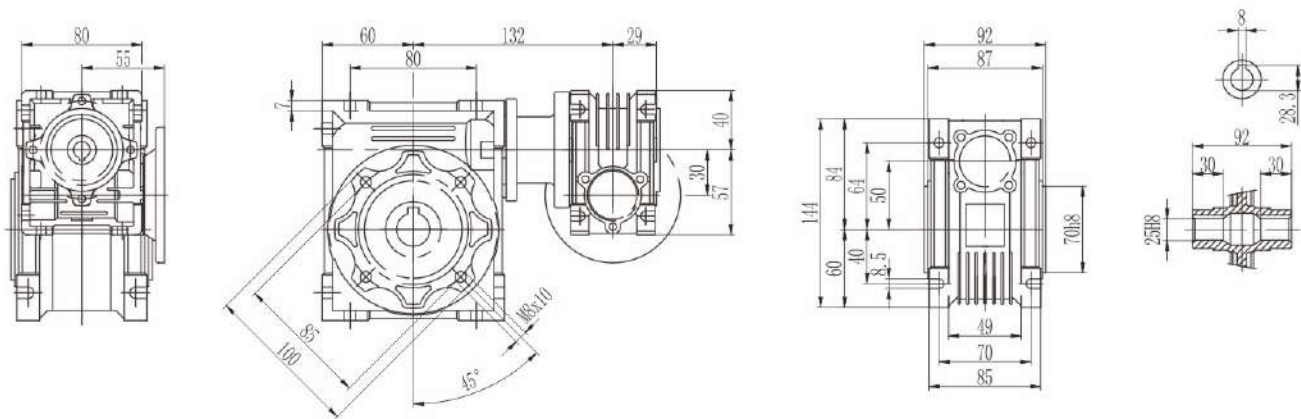

NMRV030-NMRV063

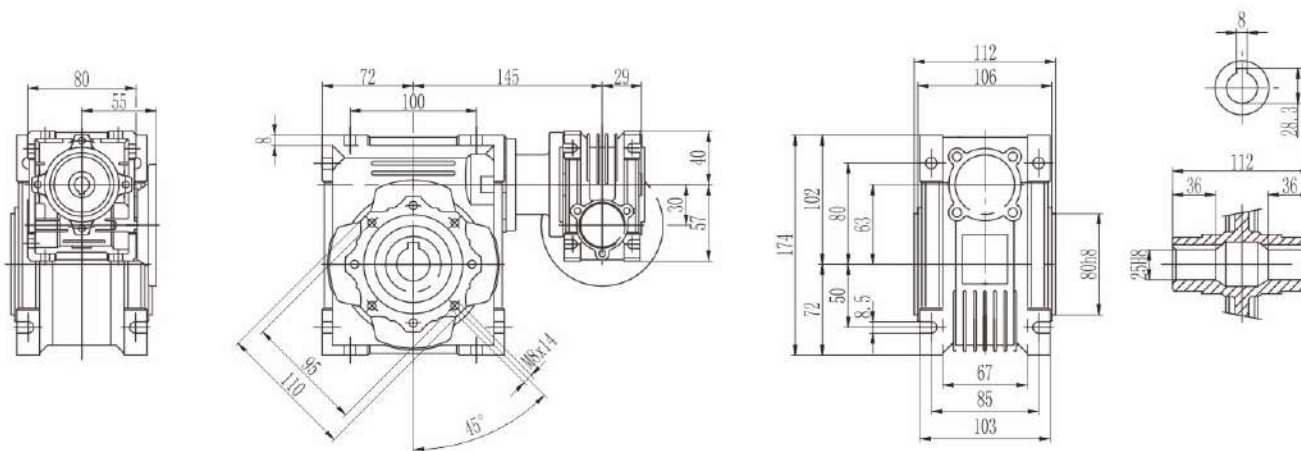

NMRV040-NMRV075

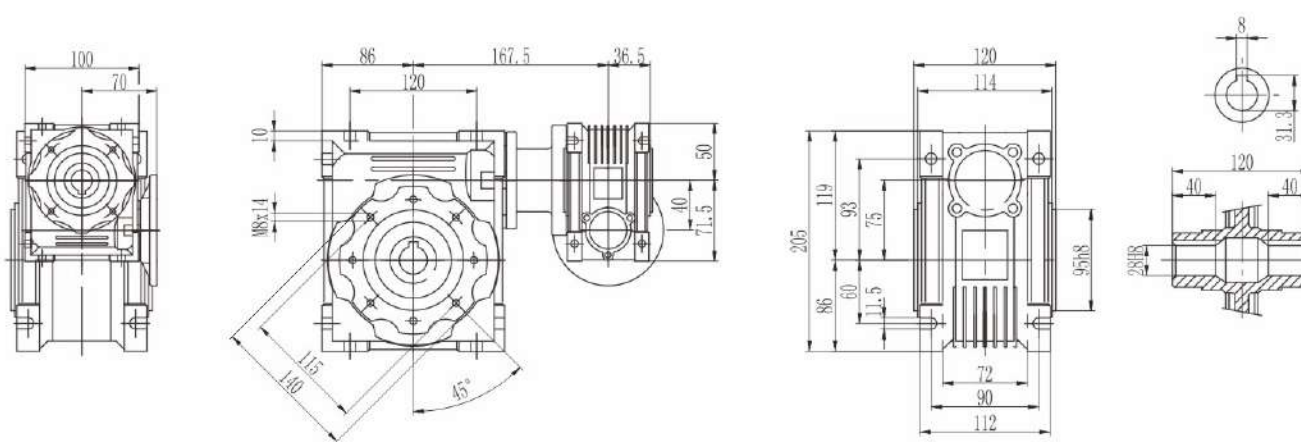

NMRV-NMRV外型尺寸 Dimensions

NMRV040-NMRV090

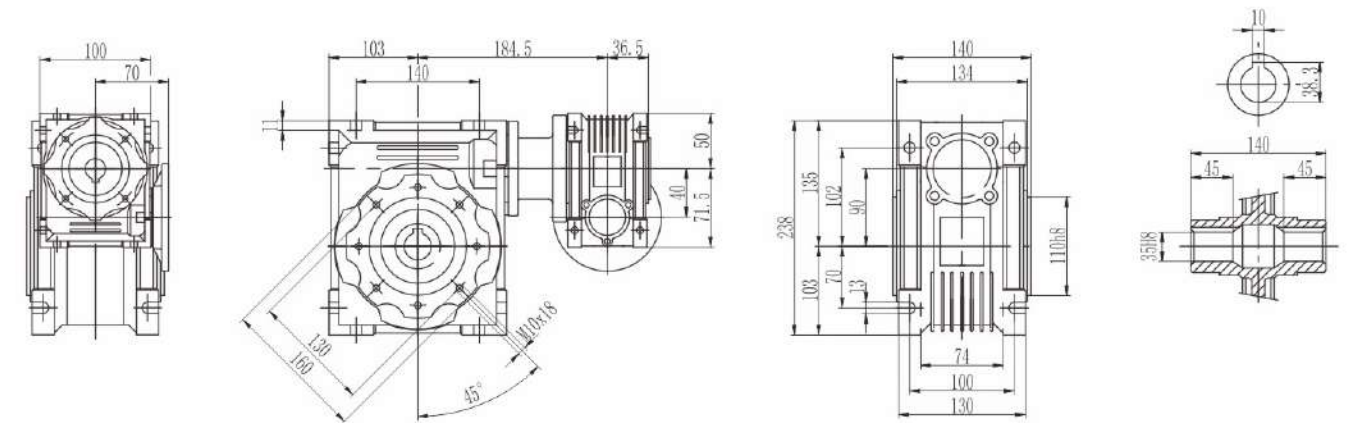

NMRV050-NMRV110

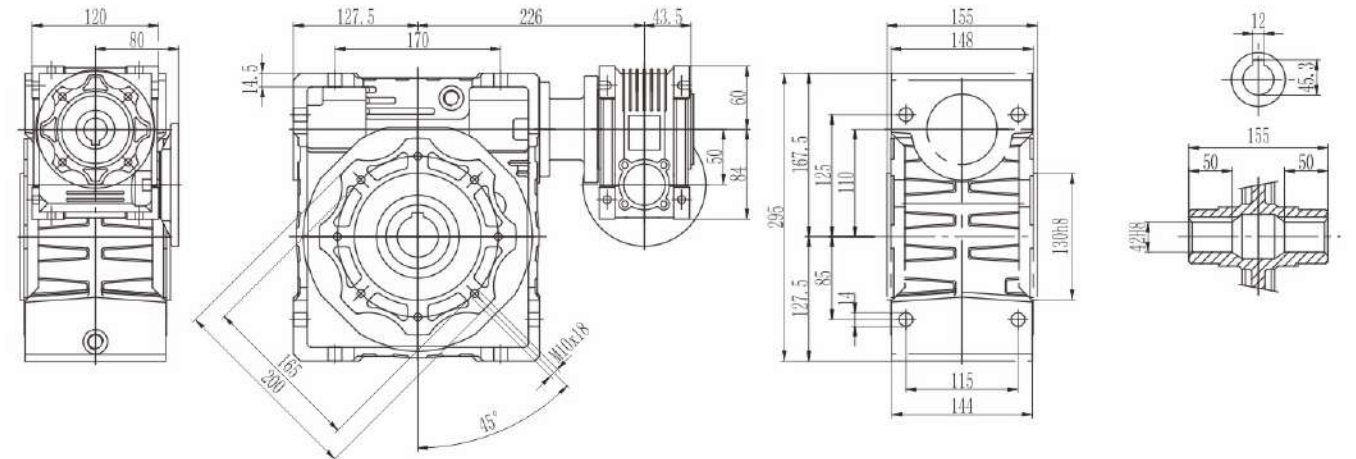

NMRV063-NMRV130

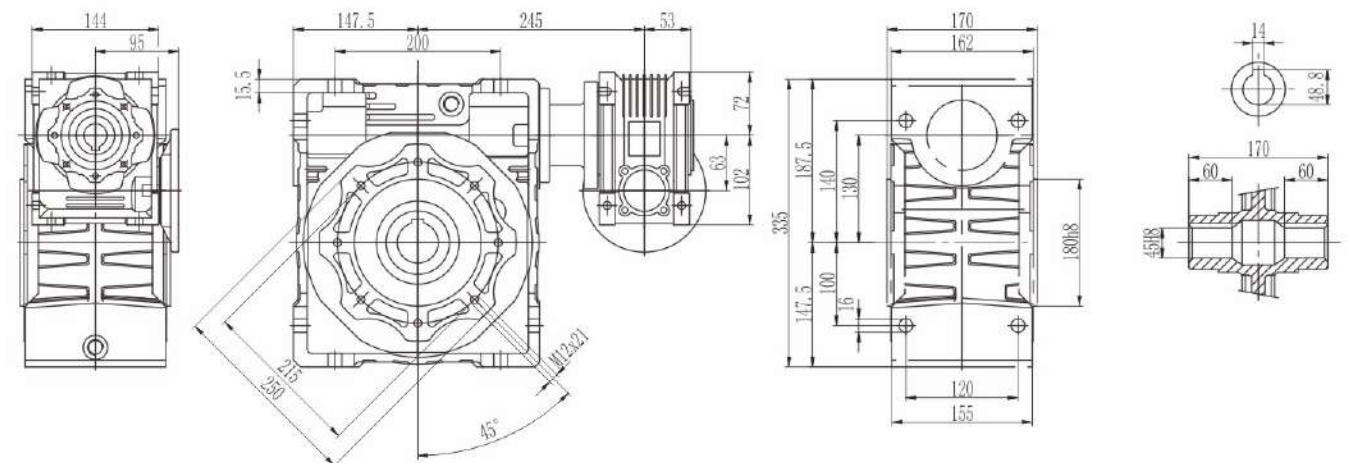

NMRV-NMRV外型尺寸 Dimensions

NMRV063-NMRV150

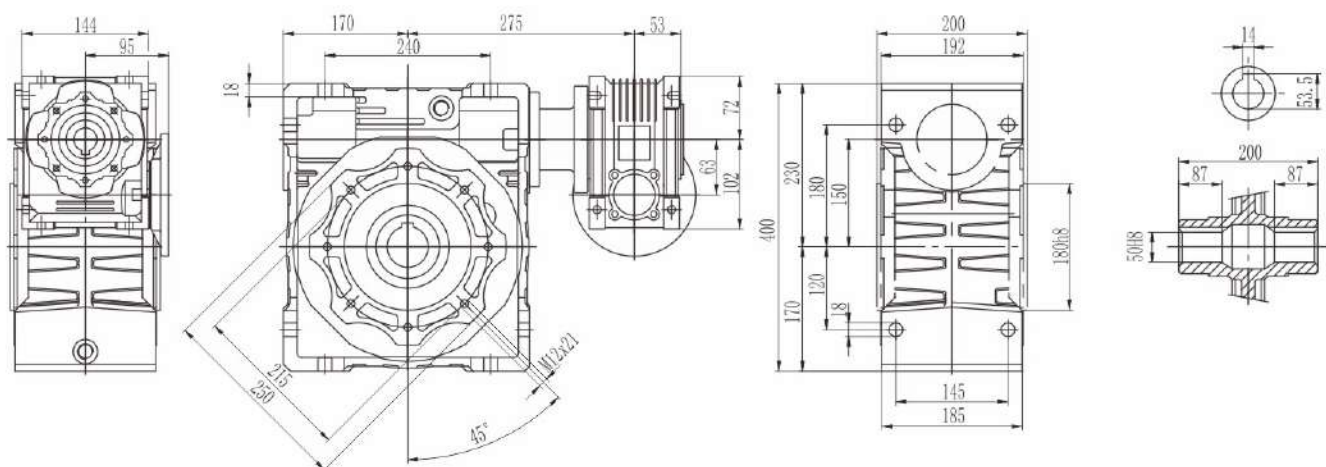

NRV-NMRV外型尺寸 Dimensions

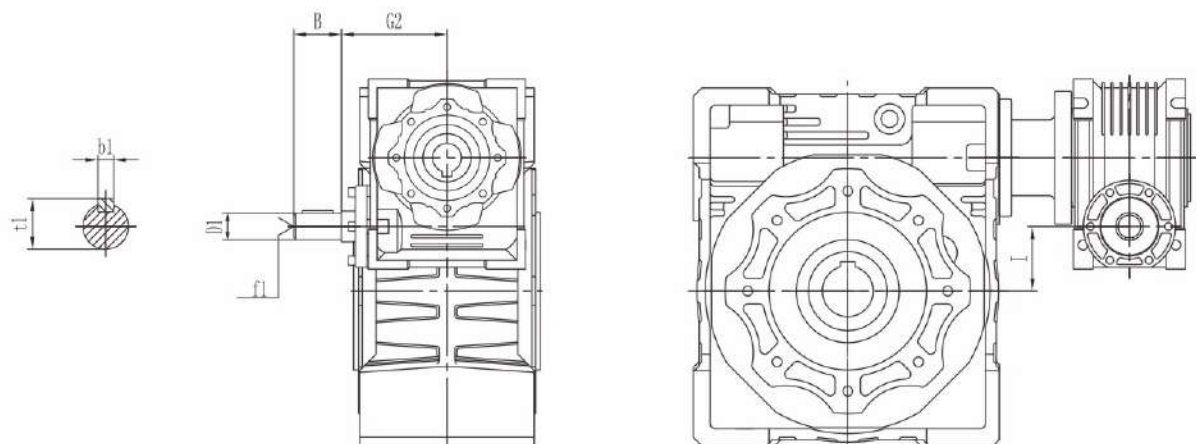

NRV-NMRV	025-030	025-040	030-040	030-050	030-063	040-075	040-090	050-110	063-130	063-150
B	20	20	20	20	20	23	23	30	40	40
D1	9 j6	9 j6	9 j6	9 j6	9 j6	11 j6	11 j6	14 j6	19 j6	19 j6
G2	42	42	51	51	51	60	60	74	90	90
l	5	15	10	20	33	35	50	60	67	87
b1	3	3	3	3	3	4	4	5	6	6
f1	-	-	-	-	-	-	-	M6	M6	M6
t1	10.2	10.2	10.2	10.2	10.2	12.5	12.5	16	21.5	21.5

附件

Accessories

防护罩 Protective cover

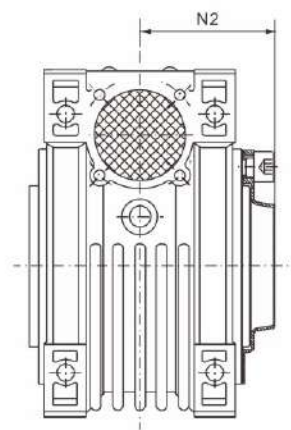

	N2
030	42
040	50
050	58
063	69
075	74
090	86
110	94
130	102
150	117

基座 Base plate

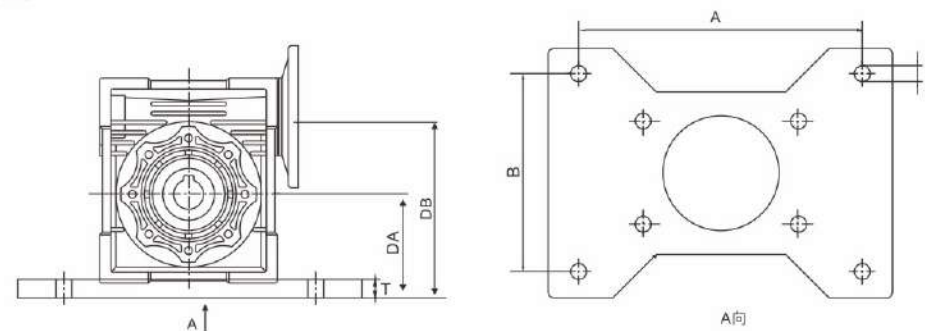

	030	040-A	040-B	050	063-A	063-B	075	090
A	111	111	146	162	179	203	214	241
B	84	84	114	119	124	133	149	156
C	8.5	8.5	10.5	12.5	12.5	12.5	12.5	12.5
DA	57	67	70	76	89	93	101.5	117.5
DB	87	107	110	126	152	156	176.5	207.5
T	17	17	20	16	17	21	15.5	14.5

扭力臂尺寸 Size of torque arm

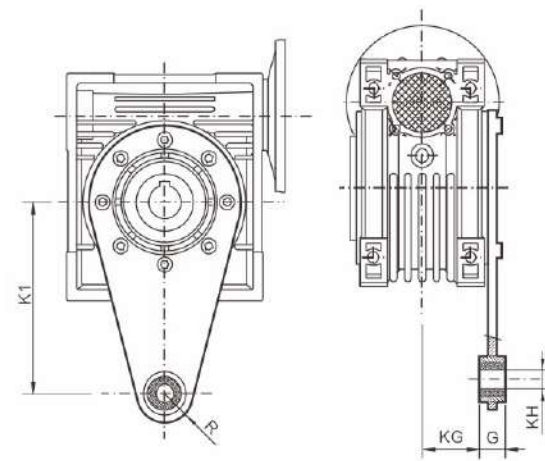

	K1	R	KG	G	KH
025	70	15	17.5	14	8
030	85	15	24	14	8
040	100	18	31.5	14	10
050	100	18	38.5	14	10
063	150	18	49	14	10
075	200	30	47.5	25	20
090	200	30	57.5	25	20
110	250	35	62	30	25
130	250	35	69	30	25
150	250	35	84	30	25

使用说明

Operating Instructions

1.单级蜗杆减速机

- 1.1 减速机型号25-90采用优质铝合金压铸箱体，外形轻巧美观,结构紧凑,体积小，重量轻，节省安装空间，不易锈蚀。
- 1.2 减速机型号110-150采用灰铸铁铝模铸造，外型美观坚固，可多方位安装使用。
- 1.3 散热性能好，安全可靠，效率高。
- 1.4 承载能力高，传动平稳，振动小，噪音低。
- 1.5 具有动力输入及转矩输出的多种联接结构，满足多种联接需要;箱体外形设计及底脚孔设置布局适应多种安装方式，通用性强。

2.双级蜗杆减速机

- 2.1 由单级蜗杆减速机组合而成，具有单级蜗杆减速机的一切优点，和获得大的传动比。
- 2.2 常用双级组合机型为: 25/30、25/40、30/40、30/50、30/63、40/75、40/90、50/110、63/130、63/150，用户若有特殊要求时,可根据实际需要选择25、30、40、50、63、75、90、110、130、150作为组合单元另行组合。

3.安装注意事项

- 3.1 减速机须安装在平整坚固的底座上，底脚螺栓必须紧固、防震。
- 3.2 原动机--减速机--工作机的各联接轴伸，去装后必须互相准确对准轴线。
- 3.3 减速机输入端及输出端轴伸外径尺寸公差按h6制作，与之相匹配的联轴器、皮带轮、链轮等传动件内孔需按合适公差尺寸配置，避免装配过紧损坏轴承，装配过松影响正常的动力传递。
- 3.4 链轮、齿轮等传动件装上轴伸时，应尽量靠近轴承，以减少轴伸弯曲应力。
- 3.5 减速机装配电机时，应在蜗杆头部内孔孔壁及键槽处涂抹黄油，避免装配过紧，防止轴孔日久生锈。
- 3.6 使用各类电机直联型减速机时，若电机重量偏大，应设支撑装置。

4.使用注意事项

- 4.1 使用前应注意检查减速机型式结构、中心距规格、传动比、输入轴连接方式、输出轴结构、输入轴输出轴轴指向和回转方向等是否符合使用要求,蜗杆输入转速不宜超过1500r/min。
- 4.2 开机时应逐步施加载荷,不能满载启动。
- 4.3 型号25-90减速机设有加油孔和放油孔，出厂时减速机内已加好ISO Vg320 润滑油，用户无需再加油,机器连续运转的500小时后,应该更换润滑油。以后换油周期为6000小时。
- 4.4 型号110-150减速机设有加油孔、放油孔和油标，减速机内已加好ISO VG460矿物润滑油，用户在使用前须拉掉通气器上橡胶环。首次运行400小时后换注新油，以后每隔约4000小时换油一次。
- 4.5 减速机允许最高油温为85℃，超过时应停机检查。
- 4.6 若减速机在使用前已放置时间超过4-6个月，而油封又未浸入润滑油中，推荐更换油封。
- 4.7 若减速机使用环境温度超出或低于表中规定使用环境温度5℃以上，请与我公司人员联系。

油品润滑

Lubricant

润滑油选用表 Lubrication oil chosen table

减速机规格 Reducer size	25-90	110-150	
润滑油类型 Type of lubrication oil	合成润滑油Complex lubrication oil	矿物润滑油Mineral lubrication oil	
环境温度℃ Ambient temperature	-25 ~ +50	-5 ~ +40	-15 ~ +25
ISO VG	ISO VG 320	ISO VG 460	ISO VG 220
AGIP	TELIUM VSF320	BLASIA 460	BLASIA 220
SHELL	TIVELA OIL Sc320	OMALA OIL 460	OMALA OIL 220
ESSO	S220	SPARTAN EP460	SPARTAN EP220
MOBIL	GLYGOYLE 320	MOBIL GEAR 634	MOBIL GEAR 630
CASTROL	ALPHASYN PG320	ALPHA MAX 460	ALPHA MAX 220
BP	ENERGOL SG-XP320	ENERGOL GR-XP460	ENERGOL GR-XP220

润滑油注油量(L) Adding capacity of lubrication oil

规格 Type 安装型式 Installation	025	030	040	050	063	075	090	110	130	150
B3	0.02	0.04	0.08	0.15	0.3	0.55	1	3	4.5	7
B6 B7								2.5	3.5	5.4
B8								2.2	3.3	5.1
V5								3	4.5	7
V6								2.2	3.3	5.1

故障分析 Malfunctions Analysis

故障情况 Fault Description	故障原因 Reasons	解决办法 Solutions
过热 Overheating	原动力、减速机、工作机连接不当 Improper connection among prime mover, reducer and the operation device	调整至适当位置, 使三者相联轴线同轴 Adjust to proper position
	超负荷运转 Overloading	适当调整负荷 Adjust to proper load
	油封过度摩擦 Over Friction of oil seals	在油封唇口处滴润滑油 Drop lubricant at oil seal
	☆ 润滑油过少或过多 ☆ Lubricant oil over much or shortage	按注油方式或调整油量 Adjust to proper oil quantity as lubricant capacity table
	☆ 润滑油杂质多或润滑性差 ☆ Much impurity in oil or inferior oil	按润滑油选用表更换合适新油 Refill proper oil
振动 Vibration	原动力、减速机、工作机固定不良 Prime mover, reducer and the operation device mount badly	查出不良固定部件, 正确固紧 Find out the bad place, tighten it
	蜗轮副齿部磨损或损伤 Tooth surface of worm gear sets worm-out or damaged	更换蜗轮副(需要时本公司配合) Replace worm gear sets (we will cooperate with you when necessary)
	轴承磨损 Bearing worn-out	更换轴承 Replace Bearing
	螺栓松脱 Bolt loose	固紧螺栓 Tighten Screw
杂音 Noise	原动机与减速机连接不当 Improper connection among prime mover, reducer and the operation device	原动机重新调整连接 Adjust to proper position
	轴承损伤或间隙过大 Bearing damaged or too large clearance	更换轴承 Replace Bearing
	蜗轮副齿合不良 Worm gear sets mesh badly	修整齿面或更换蜗轮副(请与本公司联系) Mend tooth surface or replace worm gear sets (please contact to us)
	☆ 润滑油不足 ☆ Lubricant oil shortage	按注油方式或补加润滑油 Fill in adequate oil as lubricant capacity table
漏油 Oil leakage	油封唇口磨损 Oil seal lip worn-out	更换油封 Replace oil seal
	油封档轴颈磨损 Shaft of oil seal area worn-out	更换输入轴或带轮轴蜗轮 Replace input or output shaft with worm gear
	放油螺塞未旋紧 Oil screw plug loose	螺纹处加密封胶, 旋紧螺塞 Tighten oil screw plug
	油标破损 Oil gauge damaged	更换油标 Replace oil gauge
蜗轮副 齿面磨损过快 Tooth surface of worm gear sets abrade extra-quickly	超负荷运转 Overload	调整至适当负荷 Adjust to proper loading
	☆ 润滑油不符合要求 ☆ Lubricant oil not according with requirement	更换合适的润滑油 Replace proper lubricant oil
	☆ 润滑油不足 ☆ Lubricant oil shortage	按油标指示点加足润滑油 Fill adequate oil as indication
	未按规定适时换油, 润滑油劣化 Not replacing lubricant oil in time according to requirement, oil deteriorates	按规定要求适时更换润滑油 Replacing oil in time according to requirement
	运转温度过高 Overheating while running	1. 按“过热”故障处理 2. 采取合适措施, 降低周边环境温度 1. Deal with it as "Overheating" 2. Adopting proper measures to make environment temperature fall

注: 1. ☆为换油后出现的故障原因。

2. 如果发生其他故障无法解决时, 请随时与我们联系, 以便提供咨询服务。

Annotate: 1. ☆ Accored after the lu bricant changed.

2. If other faults not listed above occur, Please contact with us at any moment, Our company will supply thorough consultation and service.

RW系列蜗轮蜗杆减速机



产品型号说明 Description of part number

RW **063** - **F1** - **AS** - **50** - **B3**

1 2 3 4 5 6

1 NMRW NRW	2 机座号 Bracket model number	3 F1 F2 无标识=不带法兰输出 No "F1" or "F2" =without output mounting flange	4 AS AB VS 无标识=不带法兰输出 No "AS", "AB" or "VS" =without output shaft	5 减速比 Ratio (i)	6 安装型式 Mounting type
-------------------------	--	--	---	------------------------------	-----------------------------------

安装型式 Mounting type

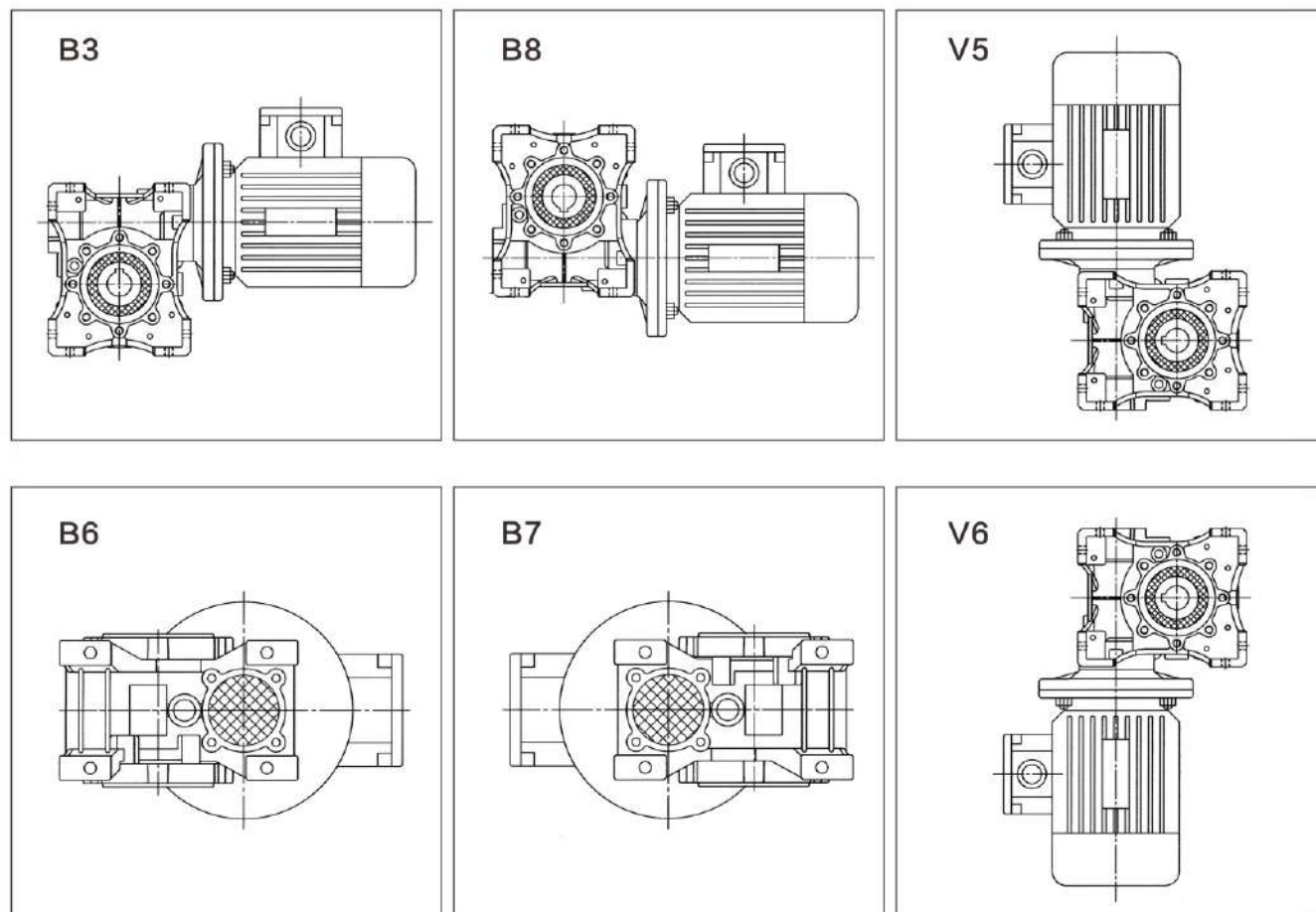

图表 Chart

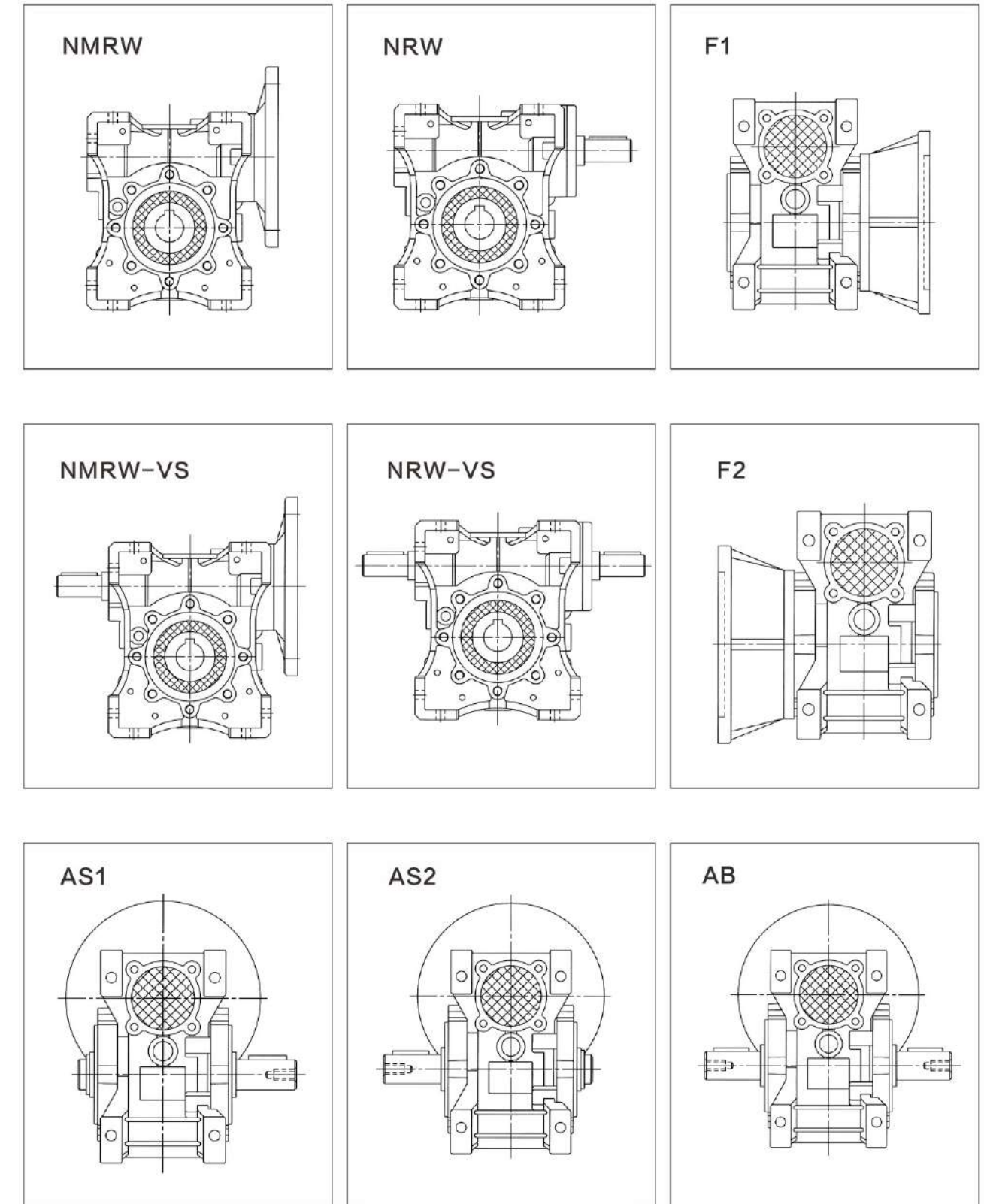

同向输出轴尺寸 Dimensions for double extension worm shaft

NRW-VS

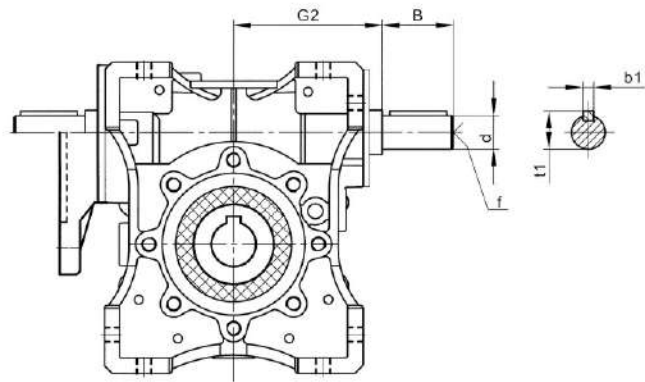

	G2	d	B	f	b1	t1
030	45	9	20	-	3	10.2
040	53	11	23	-	4	12.5
050	64	14	30	M6	5	16
063	75	19	40	M6	6	21.5
075	90	24	50	M8	8	27
090	108	24	50	M8	8	27
110	135	28	60	M10	8	31
130	155	30	80	M10	8	33
150	175	35	80	M12	10	38

单向/双向输出轴尺寸 Single / double extension output shaft

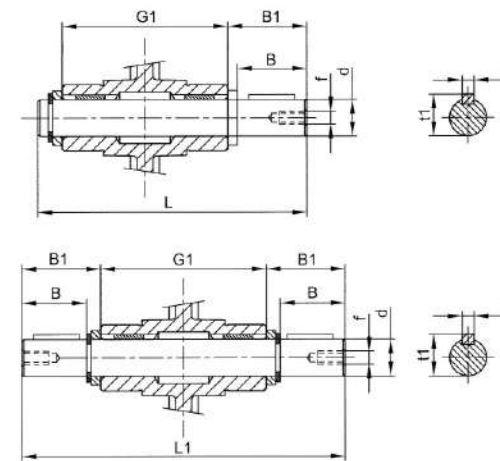

	d	B	B1	G1	L	L1	f	b1	t1
030	14h6	30	32.5	63	102	128	M6	5	16
040	18h6	40	43	78	128	164	M6	6	20.5
050	25h6	50	53.5	92	153	199	M10	8	28
063	25h6	50	53.5	112	173	219	M10	8	28
075	28h6	60	63.5	120	192	247	M10	8	31
090	35h6	80	84.5	140	234	309	M12	10	38
110	42h6	80	84.5	155	249	324	M16	12	45
130	45h6	80	85	170	265	340	M16	14	48.5
150	50h6	82	87	200	297	374	M16	14	53.5

扭力臂尺寸 Sizes of torque arm

NMRW

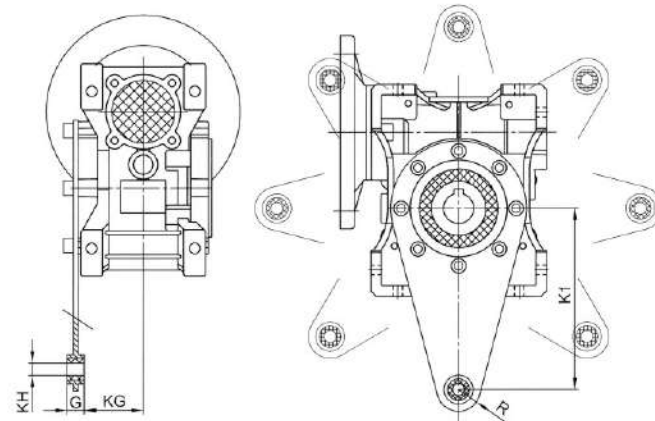

	K1	G	KG	KH	R
030	85	14	24	8	15
040	100	14	31.5	10	18
050	100	14	38.5	10	18
063	150	14	49	10	18
075	200	25	47.5	20	30
090	200	25	57.5	20	30
110	250	30	62	25	35
130	250	30	69	25	35
150	250	30	84	25	35

尺寸图 Reference dimensions

NRW-NMRW 030-150

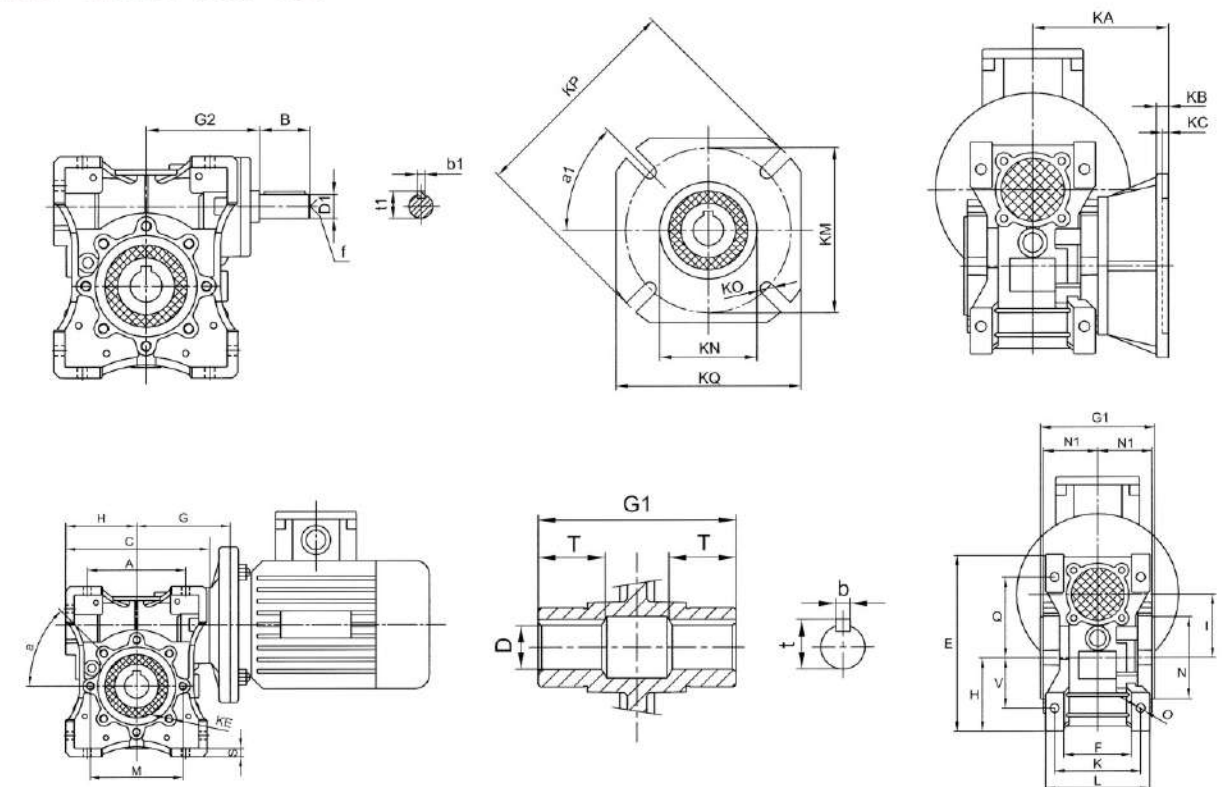

NRW / NMRW尺寸表 Dimensions for NRW / NMRW

	030	040	050	063	075	090	110	130	150
A	54	70	80	100	120	140	170	200	240
B	20	23	30	40	50	50	60	80	80
B	80	100	120	144	172	206	252.5	292.5	340
D(H8)	14	18	25	25	28	35	42	45	50
D1(j6)	9	11	14	19	24	24	28	30	35
E	97	121.5	144	174	205	238	295	335	400
F	32	43	49	67	72	74	-	-	-
G	55	70	80	95	112.5	129.5	160	180	210
G1	63	78	92	112	120	140	155	170	200
G2	51	60	74	90	105	125	142	162	195
H	40	50	60	72	86	103	127.5	147.5	170
I	30	40	50	63	75	90	110	130	150
L	56	71	85	103	112	130	144	155	185
M	65	75	85	95	115	130	165	215	215
N(h8)	55	60	70	80	95	110	130	180	180
N1	29	36.5	43.5	53	57	67	74	81	96
O	6.5	6.5	8.5	8.5	11	13	14	16	18
Q	44	55	64	80	93	102	125	140	180
S	5.5	6.5	7	8	10	11	14	15	18
T	21	26	30	36	40	45	50	60	72.5
V	27	35	40	50	60	70	85	100	120
K	44	60	70	85	90	100	115	120	145
KE	M6X11 {n=4}	M6X8 {n=4}	M6X10 {n=4}	M8X14 {n=8}	M8X14 {n=8}	M10X18 {n=8}	M10X18 {n=8}	M12X21 {n=8}	M12X21 {n=8}
a	0	45°	45°	45°	45°	45°	45°	45°	45°
KA	54.5	67	90	112	111	111	131	140	155
KB	6	7	9	10	13	13	15	15	15
KC	4	4	5	6	6	6	6	6	6
a1	45°	45°	45°	45°	45°	45°	45°	-	-
KM	68	80	90	150	165	175	230	255	255
KN(H8)	50	60	70	115	130	152	170	180	180
KO	6.5(n.4)	9(n.4)	11(n.4)	11(n.4)	14(n.4)	14(n.4)	14(n.8)	16(n.8)	16(n.8)
KP	80	110	125	180	200	210	280	320	320
KQ	70	95	110	142	170	200	260	290	290
b	5	6	8	8	8	10	12	14	14
b1	3	4	5	6	8	8	8	8	10
f	-	-	M6	M6	M8	M8	M10	M10	M12
t	16.3	20.8	28.3	28.3	31.3	38.3	45.3	48.8	53.5
t1	10.2	12.5	16	21.5	27	27	31	33	38

齿轮减速电机 / Gearmotors

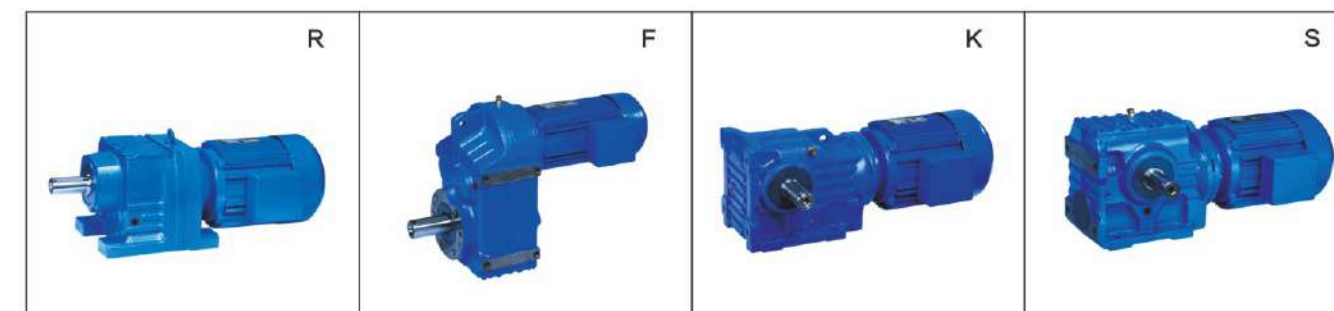

WP系列蜗轮蜗杆减速机 / WP Series Worm Gear Speed Reducer



SWL系列蜗轮丝杆升降机 / SWL Series Worm Gear Screw Jack



HK系列蜗轮丝杆升降机 / HK Series Worm Gear Screw Jack

